



2. Addressed Mail

| | |
|---|----|
| Creation - Small Format | 1 |
| Creation - Large Format | 12 |
| Creation - Large+ Format | 31 |
| Mail Item Format Overview | 38 |
| Mail ID Technology | 40 |
| Preparing your mail items - Packaging | 46 |
| Preparing your mail items - Sorting options | 62 |
| Depositing your mail items | 84 |

Table of contents

Creation - Small Format

| | |
|--|----------|
| 1. Criteria and characteristics | 1 |
| 1.1 Dimensions, weight & thickness | 1 |
| 1.2 Characteristics | 2 |
| 2. Visual presentation of your mail items | 3 |
| 2.1 Front | 3 |
| 2.1.1 Zones on the front of the envelope | 3 |
| a. When the address is not displayed in a window | 3 |
| b. When the address is displayed in a window | 5 |
| 2.2 Back | 6 |
| 2.3 Advertising windows | 6 |
| 2.3.1 On the front | 6 |
| 2.3.2 On the back | 7 |
| 3. Sealing methods for mail items | 8 |
| 4. Paper characteristics | 8 |
| 5. Features of open mail items (self-mailers and postcards) | 8 |
| 5.1 Self-mailers | 8 |
| 5.1.1 General guidelines for sealing | 9 |
| 5.1.2 Sealing methods – examples | 9 |
| 5.2 Postcards | 10 |

Creation - Large Format

| | |
|--|-----------|
| 1. Criteria and characteristics | 12 |
| 1.1 Dimensions, weight & thickness | 12 |
| 1.2 Characteristics | 13 |
| 2. Visual presentation of your mail items | 14 |
| 2.1 Front | 14 |
| 2.1.1 Zones on the front of the mail item | 14 |
| a. When the address is not displayed in a window | 14 |
| b. When the address is displayed in a window | 16 |
| 2.2 Back | 18 |
| 2.3 Advertising windows | 18 |
| 2.3.1 On the front | 18 |
| 2.3.2 On the back | 19 |
| 3. Sealing methods for mail items | 20 |
| 4. Paper characteristics | 20 |

Table of contents

| | |
|---|-----------|
| 5. Features of open mail items (self-mailers, postcards and mail items with visible binding) | 20 |
| 5.1 Self-mailers | 20 |
| 5.1.1 Examples of sealing methods | 21 |
| 5.2 Postcards | 22 |
| 5.3 Bound mail items sent without envelope or wrapper | 23 |
| 5.3.1 Using a white label for the recipient address | 24 |
| 5.3.2 Recipient address on the back of the mail item | 25 |
| 6. Specifications for mail items wrapped in plastic film | 26 |
| 6.1 Printing the recipient address | 26 |
| 6.1.1 Printing the address ON the plastic film | 26 |
| 6.1.2 Printing UNDER the plastic film | 26 |
| 6.2 Positioning of the recipient address, return address and franking mark | 27 |
| 6.2.1 General guidelines | 27 |
| 6.2.2 Use of an opaque white strip on the plastic film | 27 |
| 6.2.3 Use of a flyleaf under the plastic film | 29 |
| 6.2.4 Recipient address on the reverse of the sending | 30 |
| 6.3 Technical specifications for plastic film (bpost technical standards) | 30 |
| | |
| Creation - Large+ Format | |
| 1. Type of sendings | 31 |
| 1.1 Square or rectangular | 31 |
| 1.1.1 Dimensions, weight & thickness | 31 |
| 1.2 Forms other than square or rectangular | 32 |
| 1.2.1 Dimensions, weight & thickness | 32 |
| 1.2.2 Rounded and angular items | 32 |
| 1.2.3 Examples | 33 |
| 2. Characteristics | 34 |
| 3. Visual presentation of your mail items | 34 |
| 4. Sealing methods for mail items | 35 |
| 5. Paper characteristics | 35 |
| 6. Features of open mail items (self-mailers, postcards and mail items with binding) | 35 |
| 6.1 Self-mailers | 35 |
| 6.1.1 Examples of sealing methods | 36 |
| 6.2 Postcards | 36 |
| 6.3 Bound mail items without envelope or wrapper | 36 |
| 6.3.1 Using a white label for the recipient address | 36 |
| 6.3.2 Recipient address on the back of the mail item | 36 |

Table of contents

| | |
|--|-----------|
| 7. Specifications for mail items wrapped in plastic film | 37 |
| 7.1 Positioning of the recipient address, return address and the franking mark | 37 |
| 7.2 Technical specifications for plastic film | 37 |

Mail Item Format Overview

| | |
|-----------------------------------|-----------|
| Format Summary Table | 38 |
|-----------------------------------|-----------|

Mail ID Technology

| | |
|--|-----------|
| 1. Definition and scope of Mail ID Technology | 40 |
| 2. Certification | 40 |
| 3. Electronic address file exchange system | 41 |
| 3.1 The answer file (Response) | 41 |
| 3.1.1 Sorting plan Small V1 or V2 | 42 |
| 3.1.2 Round and sequence sorting V3 | 42 |
| a. The Large Format and Large+ Format sorting plan rule | 42 |
| b. The sequence reference code | 42 |
| 4. Printing the mail ID barcode and the sequence reference code | 43 |
| 4.1 Mail ID barcodes | 43 |
| 4.2 RSV3 sequence reference | 44 |
| 5. Mail ID addressing rules | 45 |

Preparing your mail items - Packaging

| | |
|---|-----------|
| 1. Packaging types available for your mail items | 46 |
| 1.1 Trays containers | 46 |
| 1.1.1 Blue trays | 46 |
| 1.1.2 How to deposit mail items in blue trays | 47 |
| a. Small Format mail items | 47 |
| b. Large and Large+ Format mail items | 47 |
| 1.2 Restmail Containers | 48 |
| 1.2.1 Bundling mail items - bundle characteristics | 48 |
| 1.2.2 The two bundle types | 49 |
| a. Direct bundles | 49 |
| b. Direct bundle by Round and sequence V3 | 49 |
| 1.3 Palletbox Mail | 50 |
| 1.4 Pallets | 53 |
| 1.5 Closed cardboard boxes | 54 |
| 2. Overflow | 55 |

Table of contents

| | |
|--|-----------|
| 3. How to label appropriately for different packaging | 56 |
| 3.1 Label dimensions | 56 |
| 3.1.1 Blue trays and cardboard boxes | 56 |
| 3.1.2 Containers and pallets | 56 |
| 3.2 Label content and colours | 57 |
| 4. Dealing with overflow | 58 |
| 5. Important definitions | 60 |
| | |
| Preparing your mail items - Sorting options | |
| 1. The different sorting options | 62 |
| 2. Minimum number of mail items per sorting type | 63 |
| 3. Unsorted mail items | 64 |
| 3.1 Maximum and minimum volume per deposit | 64 |
| 3.2 Packaging and labelling | 64 |
| 4. Sorted mail items per sorting plan V1 or V2 (for Small Format) | 65 |
| 4.1 Maximum and minimum volume per deposit | 65 |
| 4.2 Packaging and labelling | 66 |
| 4.2.1 In containers/on pallets by sorting plan | 66 |
| 4.2.2 In containers/on pallets by wave | 67 |
| 4.2.3 In containers/on pallets by sorting center | 68 |
| 4.2.4 In containers/on pallets in overflow | 70 |
| 5. Mail items sorted by Round and sequence V3 | 71 |
| 5.1 Minimum and maximum volume per deposit | 71 |
| 5.2 Deposit WITH bundels | 73 |
| 5.2.1 On pallets/in Restmail containers by sorting plan | 73 |
| 5.2.2 On pallets/in Restmail containers by sorting machine | 74 |
| 5.2.3 On pallets/in Restmail containers for the same distribution zone of one and the same sorting center | 75 |
| 5.2.4 On pallets/in Restmail containers with 2 distribution zones for the same sorting center | 76 |
| 5.3 Deposit NOT in bundels (in Palletbox Mail) | 77 |
| 5.3.1 In Palletbox Mail per sorting plan | 77 |
| 5.3.2 In Palletbox Mail per machine | 78 |
| 5.3.3 In Palletbox Mail of the same distribution zone for one and the same sorting center | 79 |
| 5.3.4 In Palletbox Mail with 2 distribution zones for the same sorting center | 80 |
| 5.4 On pallets/in containers with overflow trays | 81 |
| 6. Annex | 83 |

Table of contents

Depositing your mail items

| | |
|--|-----------|
| 1. Definition of a deposit | 84 |
| 1.1 Definition of a deposit | 84 |
| 1.2 The various stages of a deposit (depending on the product in question) | 85 |
| 2. e-Masspost, the online app for scheduling and announcing your deposits | 86 |
| 2.1 Services available via e-Masspost | 86 |
| 3. Process for scheduling a deposit | 87 |
| 3.1 Basic rule | 87 |
| 3.2 For certain bpost items, there is a required scheduling process | 87 |
| 3.2.1 What is Booking? | 87 |
| 3.2.2 When is Booking compulsory? | 87 |
| 3.2.3 When should Booking information be submitted? | 87 |
| 3.2.4 What information is provided at Booking? | 88 |
| 4. The deposit announcement process | 89 |
| 4.1 Making an appointment | 89 |
| 4.2 Obtaining your deposit authorisation | 90 |
| 4.2.1 via e-Masspost | 90 |
| 4.2.2 via the Masspost counter | 90 |
| 4.3 Special case of a spread deposit | 90 |
| 4.3.1 Spread deposit terms and conditions | 90 |
| 4.3.2 Procedure to be followed for spread deposits | 91 |
| 4.3.3 Identification of containers/pallets | 92 |
| 4.4 Special case of a split deposit (Split Drop) | 93 |
| 4.4.1 Conditions of the agreed split-off delivery | 93 |
| a. DM Easy and DM Boost | 93 |
| b. DM Intense | 94 |
| 4.4.2 Identification of containers/pallets | 94 |
| 4.5 The “Mixed Weight” | 95 |
| 5. Deposit and time of deposit | 96 |
| 6. Deposit checks on the dock | 96 |
| 7. Deposit summary | 96 |
| 8. Payment | 96 |
| 9. Packaging exchange procedure | 97 |
| 9.1 Pallets | 97 |
| 9.2 Containers, blue trays and Palletboxes Mail | 98 |
| 9.3 Bags | 98 |

Creation - Small Format

1. Criteria and characteristics

1.1 Dimensions, weight & thickness

A **Small Format** mail item must rigorously comply with all of the criteria set out below.

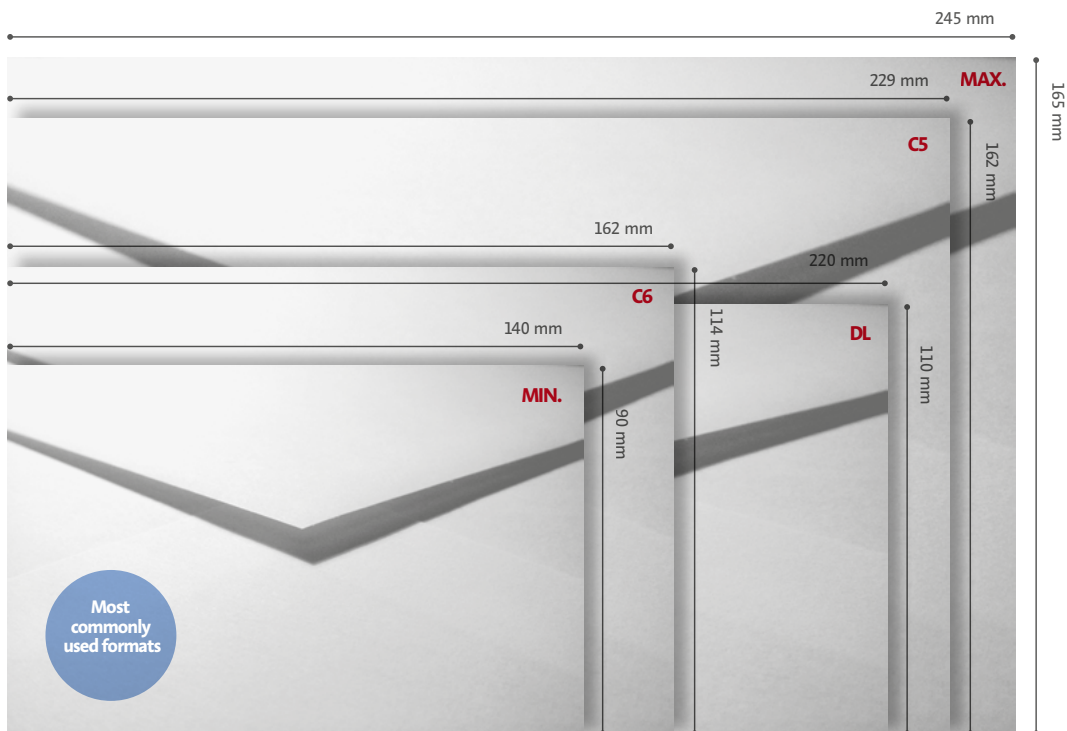

Minimum and maximum dimensions for **Small Format** mail items.
This illustration is also included in the **General Annexes**, showing actual sizes.

| | |
|---|--|
| Shape | Rectangular (never square) |
| Dimensions | Minimum (width) 90 x (length) 140 x (thickness) 0.15 mm Maximum (width) 165 x (length) 245 x (thickness) 5 mm |
| Weight | Minimum 2 g Maximum 50 g |
| Ratio of length (longest side) / width (shortest side) | ≥ 1.20 |
| Orientation | Landscape only |
| Address box | Always parallel to the longest side of the mail item |

In the case of **Small Format**¹, mail item sorting, transport and delivery are optimised. In addition to the criteria outlined above, to be considered a Small Format item, mail items must comply with the various different characteristics summarised in this chapter on visual presentation, closure and paper characteristics.

1.2 Characteristics

Any item that does not share all the above-mentioned characteristics or which has one or more of the following characteristics shall automatically be deemed to be a **Large Format** or **Large+ Format** mail item. 

- rigid and/or metallic and/or cardboard mail items
- mail items containing a rigid object
- mail items open on 1 side, or more
- items bearing 1 or more repositionable stickers
- items wrapped in plastic film (bpost technical standards or otherwise)
- padded and/or bubble-wrap envelopes
- translucent, bright, varnished, glazed or glossy envelopes
- ratio of length (longest side) / width (shortest side) < 1.2 (square or virtually square shape)
- closed with staples, paperclips or metallic eyelets

If your mail item has any of the following characteristics, it shall automatically be deemed to be a **Large+ Format** mail item. 

- items containing liquids
- mail items with partially glued parts, such as cardboard, cards, envelopes, etc.
- non-rectangular and non-square items
- open or pierced mail items (e.g. windows not closed by transparent film)

¹ Take care to conform to the postal regulations and the General Terms and Conditions of bpost, especially in respect of mail item contents. The General Terms and Conditions of bpost are available at www.bpost.be/site/fr/conditions.html.

2. Visual presentation of your mail items

2.1 Front

The front of the mail item is the side bearing the recipient's address and the franking. The recipient's address may only appear once, on the front of the item. It may not appear a second time, in whole or in part, either on the front of the item or on the back.

2.1.1 Zones on the front of the envelope

a When the address is not displayed in a window

Your mail item must strictly adhere to the dimensions shown below:

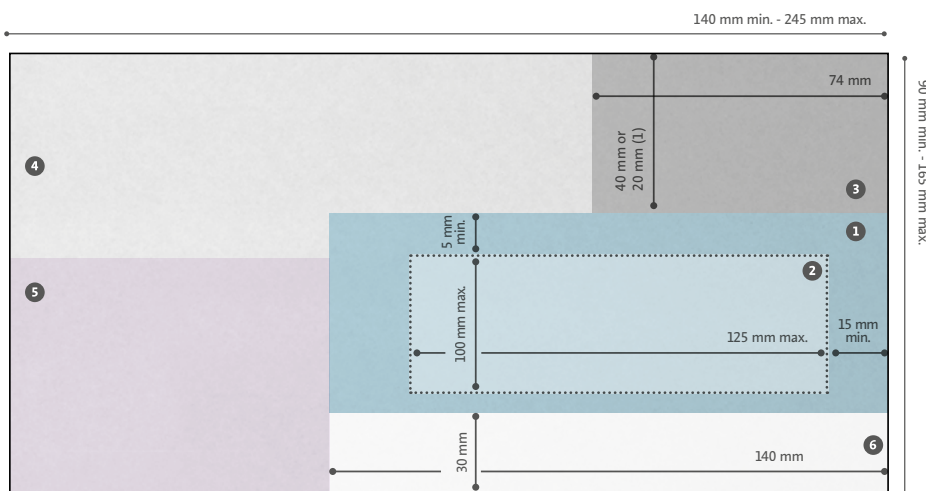

(1) 20 mm for items < 11 cm tall (40 mm for all other items).

The control code zone ⑥ is the zone in which the indexation code ('ID-tag') shall be printed when the mail item is sent through the sorting machines. This allows the mechanical processing of mail items and therefore a more timely delivery service.



① Zone for the recipient's address

- Always on the front of the envelope on the right-hand side.
- Contains the recipient's address box.
- May contain:
 - Mail ID barcodes (see the **Mail ID Technology chapter** in this section)
 - any other barcode, provided:
 - it is situated either above or below the recipient address box
 - it is situated **at least 1 cm** above this box
 - it does not start with JJBEA
 - any other references (e.g. customer number), provided:
 - they are (ideally) situated above recipient address box
 - they are situated **at least 1 cm** away from this box
 - they cannot be confused with any part of the address (e.g. postcode or municipality)

- The address must be reproduced preferably in accordance with the rules **in the Addressing chapter, section 1, Addressing and Franking point 7**, including the use of accepted background colours for the address block (Pantone colours or four-colour equivalents).
- Contains the return address, where appropriate (see **the Addressing chapter, section 1, Addressing and Franking, point 6**).

2 Recipient address box

- A virtual box (in the zone 1 intended only for the recipient's address).
- Must not contain any text or graphics other than the recipient's address.
- An opaque address label may be used, so long as it does not encroach upon the recipient address zone or franking zone.
- The recipient address must be perfectly legible to the naked eye (see **the Addressing chapter, section 1, Addressing and Franking, point 3**).

3 Franking and cancelling zone

- Franking must be perfectly legible to the naked eye (to ensure they can be read by the machine thus ensuring efficient mail item delivery):
 - all characters must be printed in the same font and font size
 - character height ≥ 1.5 mm
- Franking position:
 - upper right-hand corner of the envelope
 - within a virtual rectangle:
 - rectangle length = 74 mm from the right-hand edge of the envelope
 - rectangle width = 20 mm (mailing items of width < 11 cm) or 40 mm (in all other cases) from the upper edge of the envelope
- If using the CO₂ Compensation option, the logo must be positioned left of the Postage Paid franking label.

4 Free zone for the sender

- All colours, graphics and text types are permitted.

5 Semi-free zone for the sender

- All colours, graphics and text types are permitted, other than any elements that could be confused with an address (postcode with municipality or full address¹). Otherwise, mail items will be deemed **Large** or **Large+ Format** items.
- A return address may be written on a vertical line to the left of the address box (see **the Addressing chapter, section 1, Addressing and Franking, point 6**).

6 Control code zone

- Zone in which the control code shall be printed when the mail item is sent through the sorting machines and also reserved for the re-addressing of the mail item if the recipient has moved.
- The rules to be followed:
 - no plastic window
 - no address (or elements that could be confused with an address (postal code or city or full address))
 - otherwise the mail item will be considered as **Large+ Format**
 - no graphic elements or text
 - white or light colour (see **section 1 paragraph 7** for permitted colours)
 - otherwise the mail item will be considered as **Large Format** (exception: items with a readable Mail ID barcode)

Important reminder

To make it easier to read the address block, do not place anything² (graphics, text, references.....) at less than 1 cm all around.



¹ Exception: stating only the municipality will not result in the item being redefined in a different item category.

² Except for Mail ID barcode, if applicable, see **chapter MailID technology**.

b When the address is displayed in a window

For mail items with a rectangular address window, there is no limit to the size of the window. The window must not under any circumstances encroach upon the control code zone (otherwise the mail item shall be considered a **Large+ Format** item).

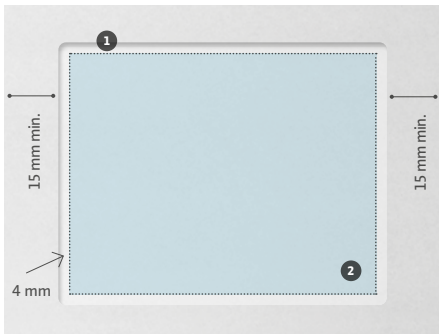

- ❶ Window
- ❷ Recipient address box

The window and the address box must however comply with the following criteria:

- A 4 mm margin is required between the edges of the window ❶ and the outside edges of the item ❷.
- It may be positioned on either the left or right side of the envelope, so long as it complies with the following rules:
 - positioned at least 15 mm from the left or right edge
 - never placed in the control code zone
- It must be closed with a transparent film.
- The edges of the transparent film must be completely glued along the inside of the envelope cut-out. If this is not the case, the mail item will be deemed a **Large+ Format** mail item (pierced or open mail item).
- It must not be creased and must not be edged with a strip or a coloured frame.
- The address must be on completely white or pale-coloured plain paper (see pantone colours) (no lined or graph paper) and must always be visible, even in the event of slipping of the contents in the envelope.
- Non-rectangular (e.g. square or oval) formats if they fit within a rectangle of the following maximum dimensions: 125 mm (length) x 100 mm (width).

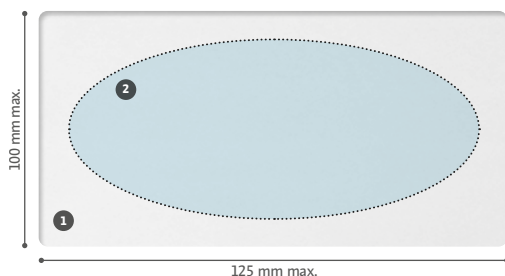

- ❶ Zone for the window with the recipient's address
- ❷ Window

The rules of zones ❷ to ❹ of the previous scheme (see above, point a) must be respected

2.2 Back

You are permitted to print text or images on the back of your mail items, or use one or more advertising windows (or picture windows), so long as they comply with the conditions of **point 2.3** below.

A return address situated in Belgium must be shown on all mail items. It is recommended that the return address is displayed on the back of your mail item, centred on the upper part, on 3 lines. For more information on the return address, see **the Addressing chapter, section 1, Addressing and Franking, point 6**.



2.3 Advertising windows

Advertising windows usually contain advertising or promotional information. They optimise the impact of your mail items.

Advertising window properties

- Windows must be closed by transparent film (otherwise the mail item will be deemed a **Large+ Format** mail item, on the basis that it is a pierced or open mail item).
- Mail items with no sender address window but containing at least one advertising window on the front will automatically be deemed **Large** or **Large+ Format** items.
- Advertising windows may be placed on either the front or back of a mail item, so long as they comply with the **following criteria**.

2.3.1 On the front

In zones **4** and **5** on the left hand side of the layout shown in **point 2.1.1** in accordance with the criteria for these zones.



Mail items with address displayed in a window

If the advertising window on the front has one or more elements that could be confused with an address (e.g. postcode, municipality¹ or full address), the item shall be deemed a **Large** or **Large+ Format** mail item.

¹ Exception: stating only the municipality will not result in the item being redefined in a different item category.

Exception: The return address may be written in an advertising window.

Conditions:

- must be positioned in the top left corner of the envelope
- font must be smaller than that used for the recipient address (at least 2 points smaller)
- address must never be at the same height as the recipient's address (so only in zone 4 of the diagram under **point 2.1.1 a)**

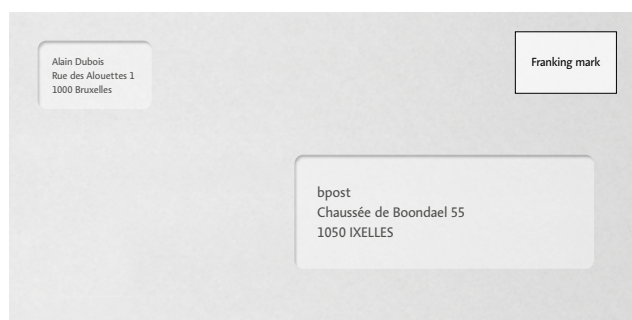

2.3.2 On the back

An advertising window may be placed freely on the back. Conditions:

- must be positioned at least 15 mm from the edges of the envelope
- small or panoramic format
- the edges of the transparent window must be completely glued along the inside edges of the envelope cut-out



3. Sealing methods for mail items

Two options for your Small Format mail items

- placed in an envelope
- sent without an envelope (as a self-mailer see **point 5.1** or a postcard see **point 5.2**)

Sealing methods

- item (and any flap) must be completely sealed on all 4 sides such that they cannot open or tear during handling
- sealing adhesive must not come into contact with any other mail item
- contents of the mail item must not come out of the envelope, nor must it be possible for them to do so
- exterior sealing strip must be robust (thickness ≥ 0.2 mm) and suitable for the content
- staples, paperclips or metallic eyelets must not be used to close the mail item

Non-compliance with any of the above criteria shall result in the item being deemed a **Large** or **Large+ Format** item.



4. Paper characteristics

- The envelope must be made of opaque matt paper (contents must not show through or be legible from the outside).
- Paper weight
 - ≥ 140 g/m² (mail items comprising a single layer of paper, e.g. postcard)
 - ≥ 70 g/m² (for mail items comprising several layers of paper, e.g. envelope or self-mailer)
- Flexible mail item (must be flexible enough to wrap around a cylinder of 21 cm circumference, e.g. 33 cl can)

Non-compliance with any of the above criteria shall result in the item being deemed a **Large** or **Large+ Format** item.



5. Features of open mail items (self-mailers and postcards)

5.1 Self-mailers

A self-mailer is an addressed and franked pre-printed leaflet. It can be sent in the mail without an envelope (or plastic film). A self-mailer is deemed to be a **Small Format** mail item if it complies fully with the defining characteristics of a Small Format mail item (see **point 1 of this chapter**), except where applicable the way it is sealed.

Did you know?

An open/pierced self-mailer is deemed to be a **Large+ Format** item.



5.1.1 General guidelines for sealing

- Robust closure (such that it cannot open or tear during handling).
- Securely sealed around all edges (the same goes for any flaps).
- 3 of the 4 sides must be completely sealed, including the right-hand side and the underside of the mail item (and ideally all 4 corners).
- The maximum distance between two adhesive points (or between a fold and an adhesive point) will be 4.5 cm.

5.1.2 Sealing methods – examples

Sealing by adhesive line or point

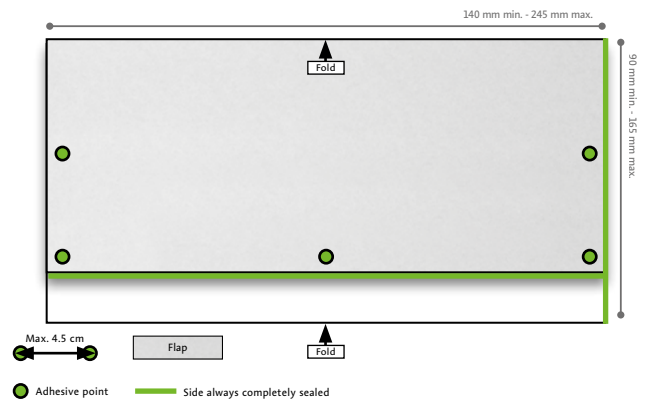

Edges sealed by stamping



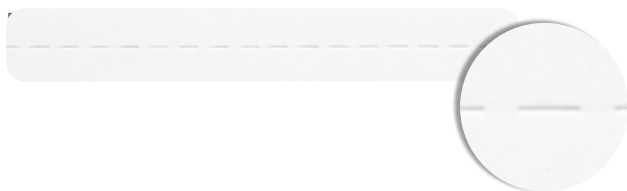

Edges with a tear line

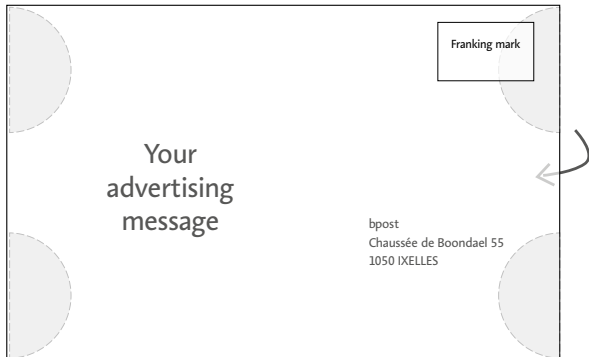

2. Addressed mail > Creation - Small Format

Sealing with self-adhesive patches (while ensuring that the 4 corners are sealed properly)



If there is any uncertainty as to whether a mail item is properly sealed with adhesive, stickers or tear strips, please note the maximum distance between two sealing points must not exceed 4.5 cm. 

5.2 Postcards

Postcards are laid out like a traditional postcard (e.g. typical holiday postcard). To be deemed a **Small Format** mail item, postcards must comply fully with the defining characteristics and criteria for a Small Format mail item (see **point 1 of this chapter**). Please also refer to the **Addressing chapter, section 1, Addressing and Franking**) for how to correctly address an item. It must also comply with the layout rules below.

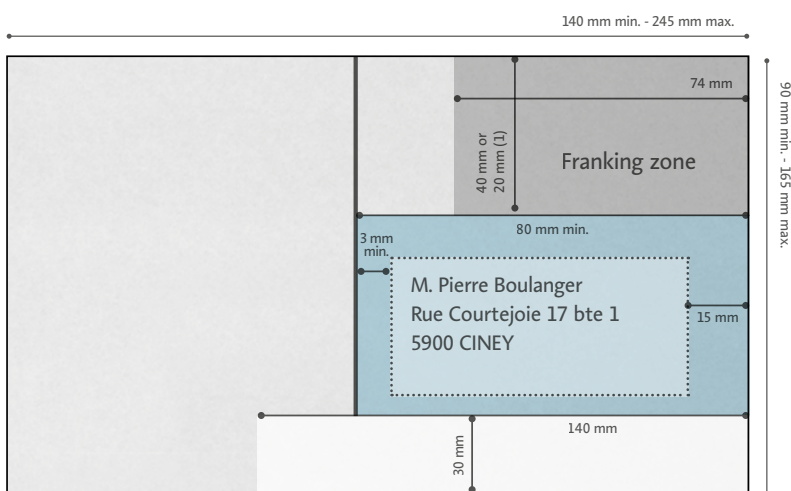

(1) 20 mm for items < 11 cm tall (40 mm for all other items).

Instructions

- the zone extending 80 mm from the right-hand edge of the card is reserved for the address and franking
- paper weight ≥ 140 g/m²
- franking to be positioned in upper right hand corner
- franking must be perfectly visible to the naked eye
- a vertical line may be used to divide the postcard into 2 areas:
 - distance ≥ 80 mm from the right-hand edge of the envelope
 - thickness ≥ 1.2 mm
 - clearly visible
 - extends over the full height of the card, terminating 30 mm from the lower edge
- address block must be at least 3 mm to the right of the dividing line
- recipient address lines must be parallel to the length of the card (landscape orientation), with no underlining
- Belgian return address goes in the top left corner (or on the back) of the card
- Return address may also be inserted vertically in a single line at least 80 mm from the right hand side

Did you know?

Open/pierced postcards are deemed to be **Large+ Format** items.

**For more information**

If you have any queries about whether a specific mail item can be handled, contact our Service Center at **02 201 11 11** or send an email to **service.centre@bpost.be**.

Creation - Large Format

1. Criteria and characteristics

1.1 Dimensions, weight & thickness

A **Large Format**¹ item must comply fully with the criteria set out in the illustration below.

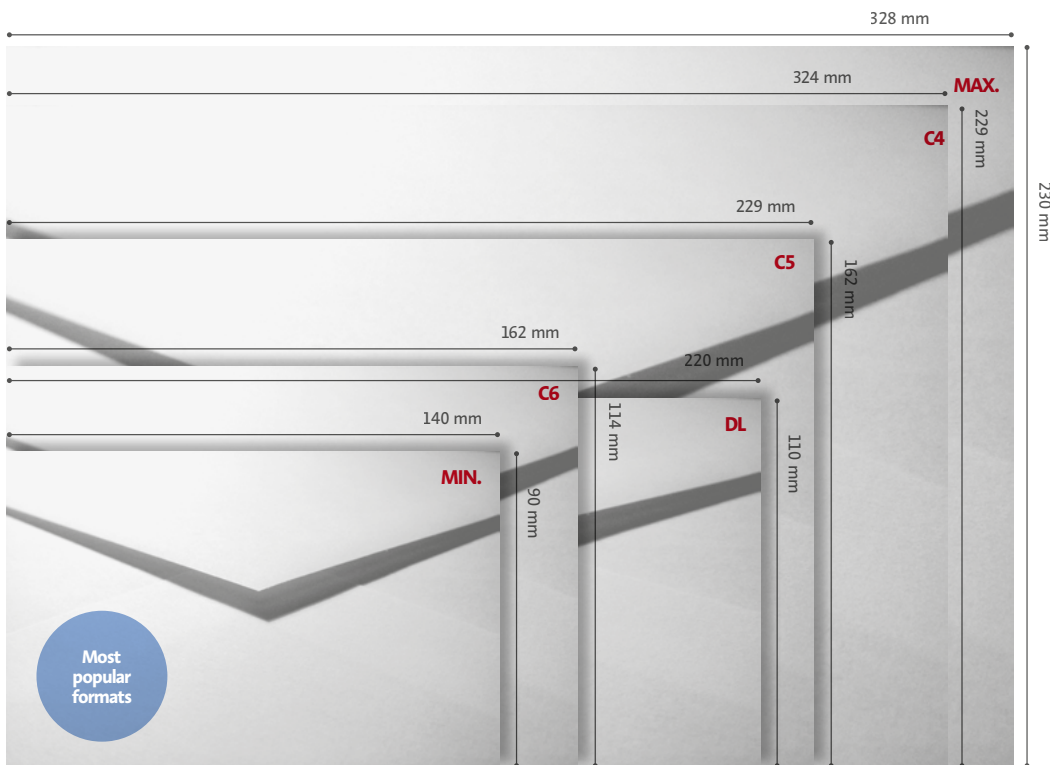

Minimum and maximum dimensions of **Large Format** mail items.

| | |
|---|---|
| Shape | Rectangular or square (with a minimum of 140 x 140 mm for square items) |
| Dimensions (inclusive of packaging) | Minimum (width) 90 x (length) 140 x (thickness) 0.15 mm Maximum (width) 230 x (length) 328 x (thickness) 10 mm |
| Poids | Recommended minimum 2 g Maximum 350 g |
| Orientation | Landscape or portrait |
| Mail items of varying width | Maximum differential of 4 mm to a total mail item height of 10 mm max |

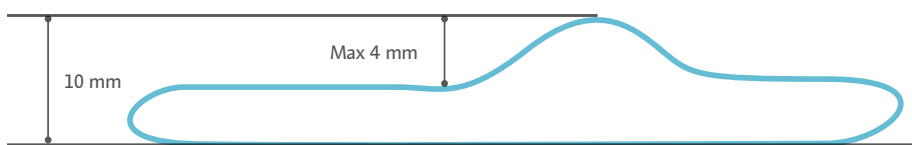

¹ Take care to conform to the postal regulations and the General Terms and Conditions of bpost, especially in respect of mail item contents. The General Terms and Conditions of bpost are available at www.bpost.be/site/fr/conditions.html.

1.2 Characteristics

Large Format specifications (exhaustive list). The following are permitted:



- rectangular, square or 'almost square' format (length to width ratio < 1.2)
- portrait orientation (address box parallel to width of the item)
- inserts or rigid objects in the mail item: if firmly affixed inside the mail item and in compliance with the variable width and flexibility/rigidity criteria (see below)
- metallized¹ and cardboard mail items, in compliance with the weight and flexibility/rigidity criteria (see below)
- mail items open on 1 side, or more (the mail item should have a closed base)
- items bearing 1 or more repositionable stickers
- plastic film-wrapped items (must be bpost technical standards compliant: see **technical specifications in Point 6.3**)
- padded and/or bubble-wrap envelopes, so long as they comply with thickness, variable width and flexibility/rigidity criteria (see below)
- translucent, bright, varnished, glazed or glossy envelopes²

Rigidity and flexibility standards for Large Format mail items

Rigidity

The sending must have a minimum of structural stiffness

- Lengthwise strength: (to be done on the bound side if there is one, or on the stronger side of the mail item) item should be flexible enough to wrap around a 900mm-diameter cylinder/sphere.

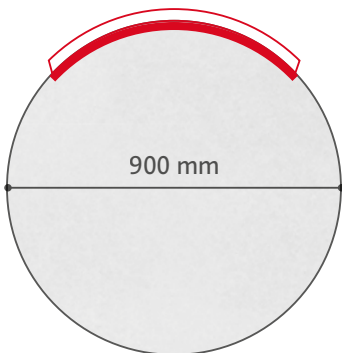

Flexibility

The sending must have a minimum of flexibility

- Place the item widthways on a flat surface such that it extends 110mm beyond the edge.
- Flex the item horizontally: the item should not bend more than 90mm above or below the flat surface.

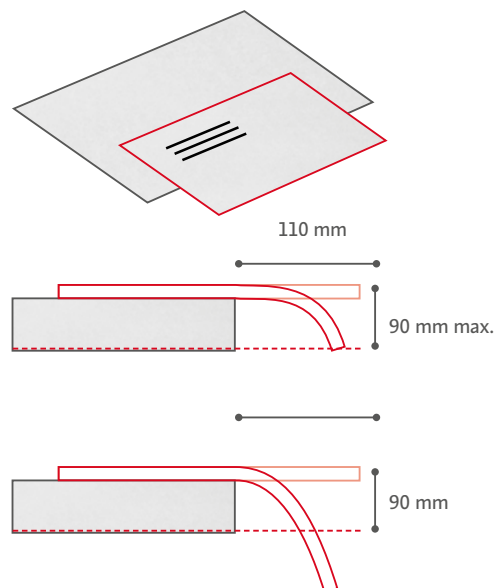

Any item which does not comply with the criteria and characteristics set out above shall be considered a **Large+ Format** mail item.



¹ For magnetic items, pre-approval is required via this address: customer.operations@bpost.be.

² Mail items which are too smooth are difficult to handle. The static friction coefficient of the exterior of the mail items must be between 0.2 and 0.4 in compliance with ISO8295 standards.

2. Visual presentation of your mail items

2.1 Front

The recipient's address may only appear once, on the front of the item. It may not appear a second time, in whole or in part, either on the front of the item or on the back.

2.1.1 Zones on the front of the mail item

a When the address is not displayed in a window

The address window must comply with the dimensions indicated below. If not, it will be considered a **Large+ Format** item.

new

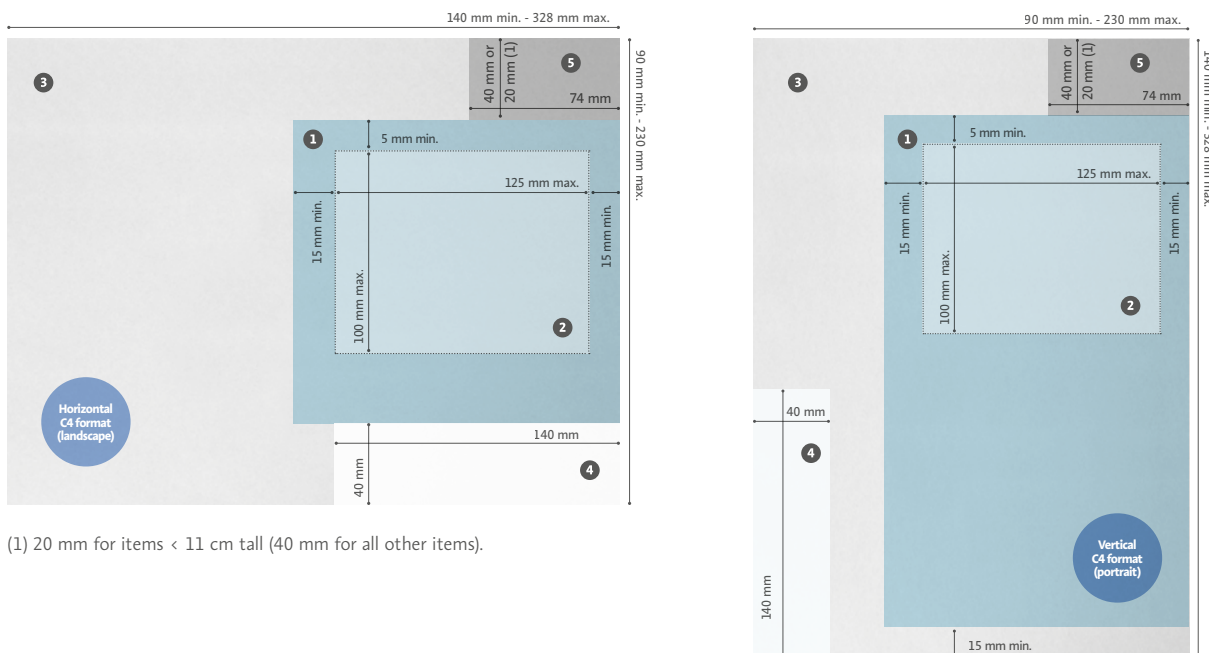

(1) 20 mm for items < 11 cm tall (40 mm for all other items).

1 Zone for the recipient's address

- Always on the front of the envelope on the right-hand side.
- Contains the recipient's address box.
- May contain:
 - Mail ID barcodes and sequence references (see the **Mail ID Technology chapter** in this section)
 - any other barcode, provided:
 - it is situated either above or below the recipient address box
 - it is situated **at least 1 cm** away from this box
 - it does not start with JJBEA
 - any other references (e.g. customer number), provided:
 - they are situated above or below the recipient address box
 - they are situated **at least 1 cm** away from this box
 - they cannot be confused with any part of the address (e.g. postcode or municipality)
- Kindly refer to the rules in **the Addressing chapter, section 1, Addressing and Franking, point 7**, including those regarding the use of accepted background colours for the address block (Pantone colours or four-colour equivalents).

2. Addressed mail > Creation - Large Format

- Contains the return address, where appropriate (see **the Addressing chapter, section 1, Addressing and Franking, point 6**).

2 Recipient address box

- A virtual box (in zone 1) intended only for the recipient's address.
- Must not contain any text or graphics other than the recipient's address.
- An opaque address label may be used, so long as it does not encroach upon the recipient address zone or franking zone.
- The recipient address must be perfectly legible to the naked eye (see the **Addressing chapter, section 1, Addressing and Franking, point 3**).

3 Free zone for the sender

- All colours, graphics and text types are permitted.

4 Control code zone

- Zone in which the control code is printed when the mail item is sent through the sorting machines.
- During mechanical sorting, the machine automatically applies the following mentions:
 - a barcode printed on the mail item
 - or a white sticker with a barcode:
 - if the mail item's paper surface is shiny or reflective
 - if the mail item is wrapped in plastic film
 - if a window is detected in this zone
 - if this zone includes images and/or is dark-coloured
- It should therefore not contain any address or address window, as it is possible they may encroach upon the control code zone and be covered by the white sticker bearing the control code.

→ If this control code zone contains an address, the mail item is considered as **Large+ Format**.

5 Franking zone

- Franking must be perfectly legible to the naked eye (all characters must be of the same font and font size, with character height ≥ 1.5 mm).
- Franking must always be positioned in the upper right hand corner of the envelope, to the right above the recipient address.
- If using the CO₂ Compensation option, the logo must be positioned left of the Postage Paid franking label.

Important reminder

To make it easier to read the address block, do not place anything (graphics, text, references... except for Mail ID barcode, if applicable (see chapter **MailID technology**)) at less than 1 cm all around.



b When the address is displayed in a window

Your mail item must comply with the dimensions shown in the diagram for mail items without an address window. For mail items with a rectangular address window, there are no restrictions on the size of the window. But it cannot encroach on the control code zone.

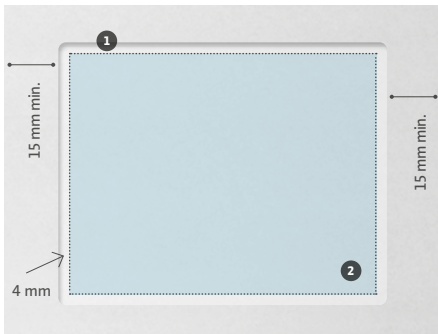

- ❶ Window
- ❷ Recipient address box

The window and the address box must however comply with the following criteria

- The window must never overlap with the control code zone (without which the mail item shall be considered a **Large+ Format**).
- A 4 mm margin is required between the edges of the window and the address box (point ❷ in the illustration).
- There must be a 15 mm margin between the right and left edges of the mail items
- It must be closed with a transparent film.
- The edges of the transparent film must be completely glued along the inside edges of the envelope window cut-out.
If this is not the case, the mail item will be deemed to be a **Large+ Format** mail item (pierced or open mail item).
- It must not be creased and must not be edged with a strip or a coloured frame.
- The complete address must always be visible through the window, even if the contents move inside the envelope.
- Text which could be confused with the address and/or postcode must not be visible in the window (e.g. if the contents move inside the envelope).
- The address must be on plain paper white or light-coloured (no lined or graph paper) and must always be visible, even in the event of slipping of the contents in the envelope.
- Non-rectangular (e.g. square or oval) formats are permitted if they fit within a rectangle measuring 125 mm x 100 mm.

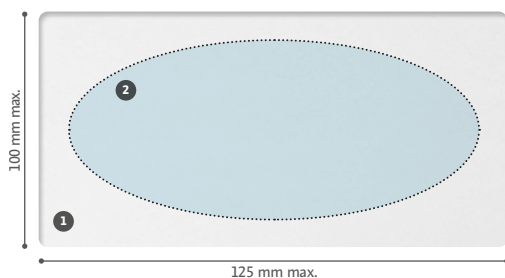

- ❶ Zone for the window with the recipient's address
- ❷ Window

Mail item zones ❷ to ❺ must comply with the same rules as a mail item without a window (see above , point a).

Instructions for placing addresses and franking marks



The mechanizable mail items are placed on the machine via the length side with the strongest side/binding at the bottom. A sticker with a barcode ('ID tag') shall be affixed, as shown in Figure 2 below (in the case of a non-free indexation zone and/or plastic film).

By following our positioning instructions according to the various illustrations in Figure 1, you can prevent the recipient's address or return address from being hidden by this sticker, preventing the mail item from not correct being delivered or returned to you because of non-delivery.

These instructions are valid for any type of **Large Format** sending.

Illustration of the feeding direction in the sorting machine (the dotted arrows illustrate the switching direction of the sending)

Figure 1: landscape or portrait

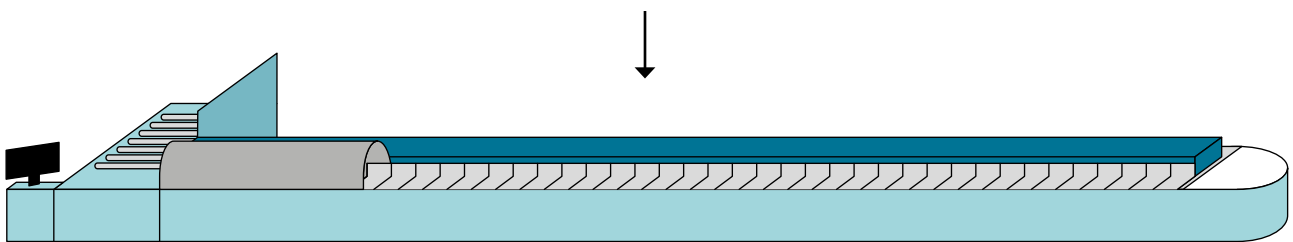
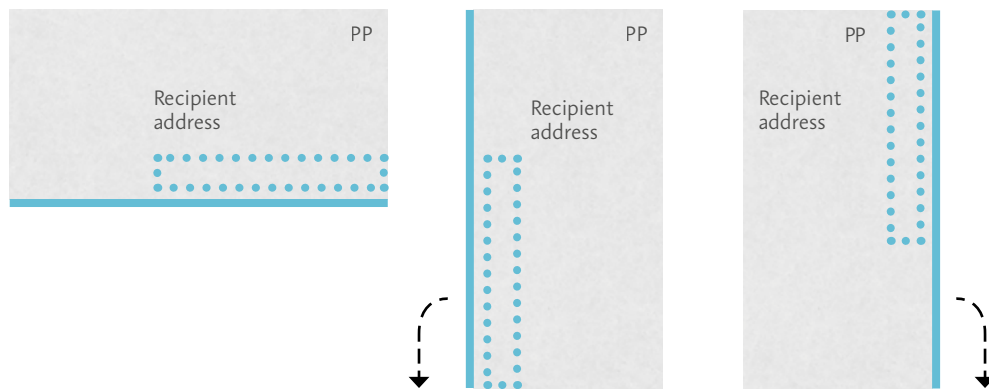

(Figure 2)

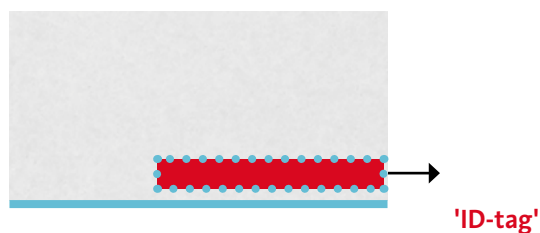

2.2 Back

Did you know?

You are permitted to print text or images on the back of your mail items, or use one or more advertising windows, so long as they comply with the stipulations of **point 2.3** below.



Positioning the return address (inclusion of which is mandatory) on the back of your mail item ensures your mail item is handled as efficiently as possible. For more return address information, see **the Addressing chapter, section 1, Addressing and Franking, point 6**.



2.3 Advertising windows

Advertising windows usually contain advertising or promotional information. They optimise the impact of your mail items.

Advertising window properties (Large Format)

- Must always be closed by transparent film (otherwise the mail item will be deemed a **Large+ Format** mail item, on the basis that it is a pierced or open mail item).
- May be placed on either the front or back of a mail item, so long as they comply with the **following criteria**.

2.3.1 On the front

There are no restrictions regarding either size or graphics (except in the address box ②, franking zone ⑤ and code control zone ④ (admitted unless an address is stated: in this case your mail item will be considered **Large+ Format**)).

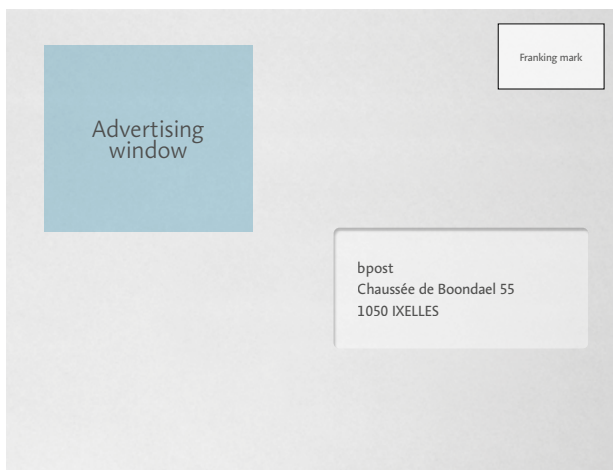

2.3.2 On the back

An advertising window may be placed freely on the back.

Conditions:

- must be positioned at least 15 mm from the edges of the envelope
- small or panoramic format
- the edges of the window film must be completely glued along the inside edges of the envelope cut-out



3. Sealing methods for mail items

Five options for your Large Format mail items

- placing in a paper or cardboard envelope
- sending without an envelope or wrapper (as a self-mailer (see **point 5.1**), a postcard (see **point 5.2**) or with visible binding (see **point 5.3**)).
- wrapping in plastic film¹ (bpost technical standards compliant, see **Point 6.3, Technical Specifications**)
- sealing with a strip or a self-adhesive system. The strip and/or self-adhesive system must adhere sufficiently to the mail item to ensure it does not move or detach during handling.
- edges sealed by stamping or tear-off strip

Sealing methods

- for mail items in cardboard or plastic envelopes, the item (and any flap) must be completely sealed on all 4 sides such that they cannot open or tear during handling
- sealing adhesive must not come into contact with any other mail item
- contents of the mail item must not come out of the envelope, nor must it be possible for them to do so
- exterior sealing strip must be robust (thickness ≥ 0.2 mm) and suitable for the content
- staples, paperclips and metal eyelets are not permitted
- staples permitted in the case of an open magazine, so long as they are attached to the binding
- no envelopes with multiple closure points (envelopes for thicker items and which can be folded)

Any item which does not comply with these criteria shall be considered a **Large+ Format** mail item.



4. Paper characteristics

Sufficiently strong and flexible mail item (see **flexibility criteria in point 1.2, p. 13**).

- Matt and opaque paper envelope
- Paper weight:
 - ≥ 140 g/m² (mail items comprising a single layer of paper, e.g. postcard)
 - ≥ 70 g/m² (for mail items comprising several layers of paper, e.g. envelope or self-mailer)

5. Features of open mail items

(self-mailers, postcards and mail items with visible binding)

5.1 Self-mailers

A self-mailer is an addressed and franked pre-printed leaflet. It can be sent in the mail without an envelope (or plastic film).

Self-mailers are deemed **Large Format** mail items, providing they:

- comply with the definition of **Large Format**
- share all **Large Format** characteristics

¹ See also the Decree of the Walloon Government of 28/02/2019 to promote the prevention of certain wastes and public cleanliness via this [link](#).

For mail items whose only 2 edges are sealed, please follow the diagrams below: 

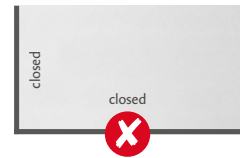

In summary

- small sides closed right and left, top and bottom open, or small left side closed = **Large+ Format**
- large bottom and small right side closed, or both large bottom and top closed = **Large Format**

Open/pierced items shall be deemed to be **Large+ Format** mail items. 

5.1.1 Examples of sealing methods

Edges sealed by stamping



Edges with a tear line



Sealed with self-adhesive patches

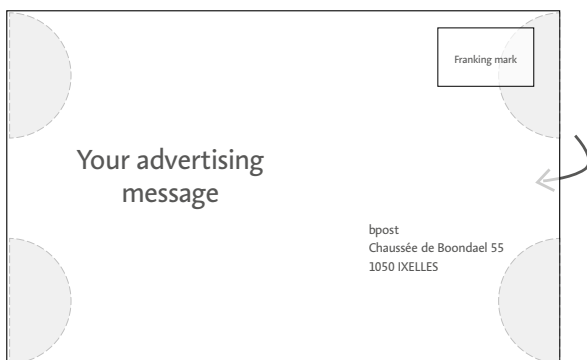

5.2 Postcards

Postcards which comply with all of the defining criteria and with at least one of the characteristics of **Large Format** mail items (e.g. weight, dimensions, etc.) are deemed to be **Large Format**.

Large Format postcards must also comply with the layout guide below.

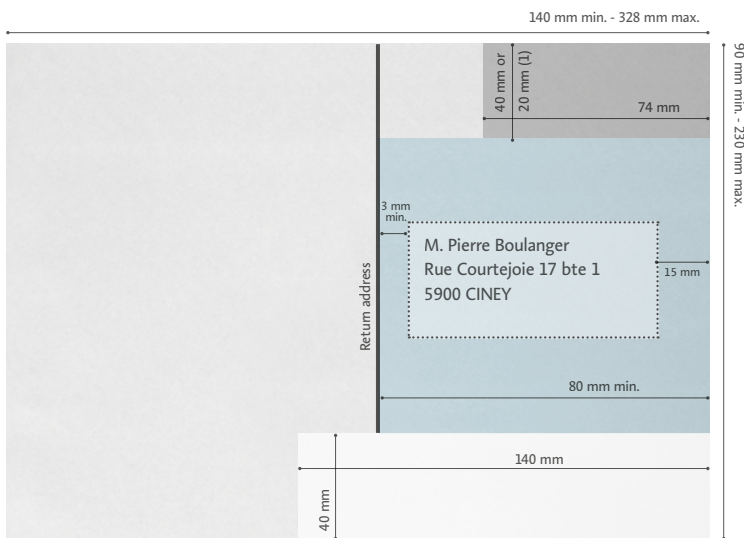

(1) 20 mm for items < 11 cm tall (40 mm for all other items).

It shares the same specifications as the **Small Format** postcard (see **point 5.2** of the **Creation - Small Format** chapter), with the exception of the possible vertical dividing line, which must be stopped at 40 mm from the lower edge of the item.

Open/pierced items shall be deemed to be **Large+ Format** mail items.



Did you know?

If you have any queries about whether an open mail item, self-mailer or postcard can be handled, contact our Service Center at **02 201 11 11** or send an email to service.centre@bpost.be.



5.3 Bound mail items without envelope or wrapper

Mail items consisting of several bound pages (not placed in an envelope or in plastic film) follow the same layout rules for the front and back of the items as items under envelope or plastic film (see **point 2 of Visual presentation of your mail items**, in this chapter).

However, please follow the following layout guidelines for the realisation of your layouts (with indication of the binding).

Landscape orientation:

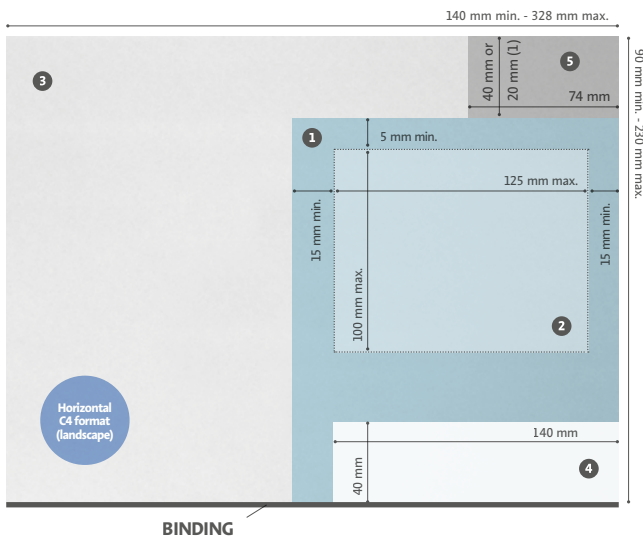

(1) 20 mm for items < 11 cm tall (40 mm for all items).

Portrait orientation:

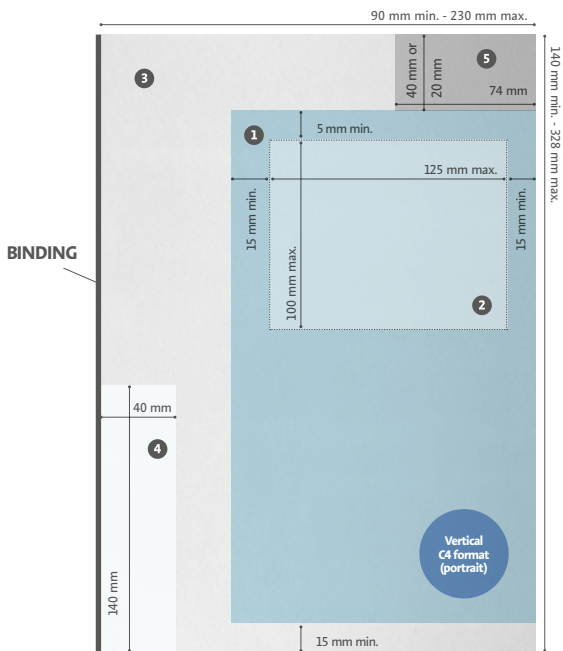

(1) 20 mm for items < 11 cm tall (40 mm for all items).

5.3.2 Recipient address on the back of the mail item

The recipient address may be placed on the back of the mail item, known as the back cover. In this case, the binding should be to the right of the mail item and the zones should be positioned according to one of the two following layouts:

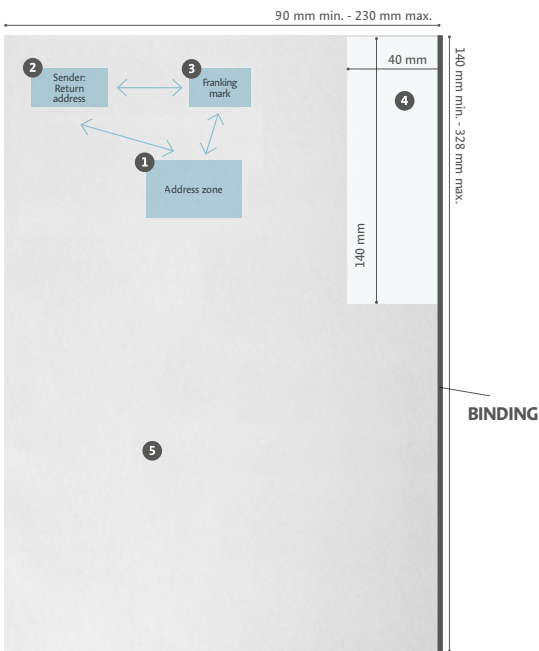

- Zone 1: for the recipient's address
- Zone 2: for the sender's address
- Zone 3: for the franking mark (PP)
- Zone 4: for the control code
- Zone 5: free zone

See the illustration of the feeding direction of the sorting machine. 

Or

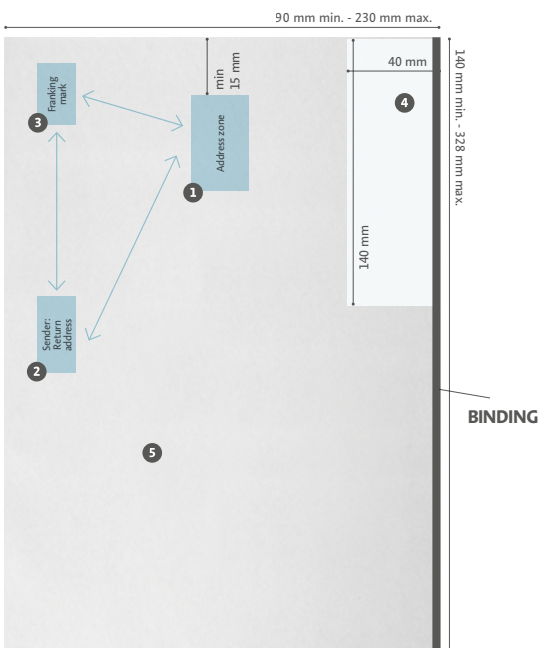

6. Specifications for mail items wrapped in plastic film¹

6.1 Printing the recipient address

6.1.1 Printing the address ON the plastic film

- Printed (ideally) on an opaque white label, affixed to the plastic film (preferable option). In such cases, the technical specifications are the same as those for open mail items (see **point 5.3.1 of point 5 above, Features of open mail items**).

Mail items in high-gloss plastic without an opaque white strip and/or those whose address label does not contrast sufficiently with the plastic shall be considered **Large+ Format** mail items.



- Printing on an opaque white band on the plastic film. See **point 6.2.2** below for technical specifications.

6.1.2 Printing UNDER the plastic film

The plastic film over the address box must be completely transparent.
The address (or any sorting code (Mail ID and R&S) may not be under the seal of the plastic film.



Option 1 (preferred) Printing the address on a flyleaf placed below the plastic film. Flyleaves must be of appropriate dimensions to ensure they do not move around inside the plastic film. See **Point 6.2.3** below for technical specifications.

Option 2 Opaque address label affixed to the mail item contents.

Option 3 Address printed directly on the mail item flyleaf.

For each option:

- To ensure that the recipient address is legible, the seal of the plastic film must not overlap the address zone.
- There must be nothing on either the front or back of the item which might be confused with the recipient address, with the possible exception of the return address (see **the Addressing chapter, section 1, Addressing and Franking, point 6**).
- Mail ID barcodes must comply with the technical specifications set out in the **Mail ID Technology chapter, point 4**.

Any item which does not comply with these criteria shall be considered a **Large+ Format** mail item.



¹ See also the Decree of the Walloon Government of 28/02/2019 to promote the prevention of certain wastes and public cleanliness via the [link](#).

6.2 Positioning of the recipient address, return address and the franking mark

6.2.1 General guidelines

It is recommended that the recipient address, franking mark and return address (if shown on the front) appear in a rectangle measuring at least 90 x 140 mm.

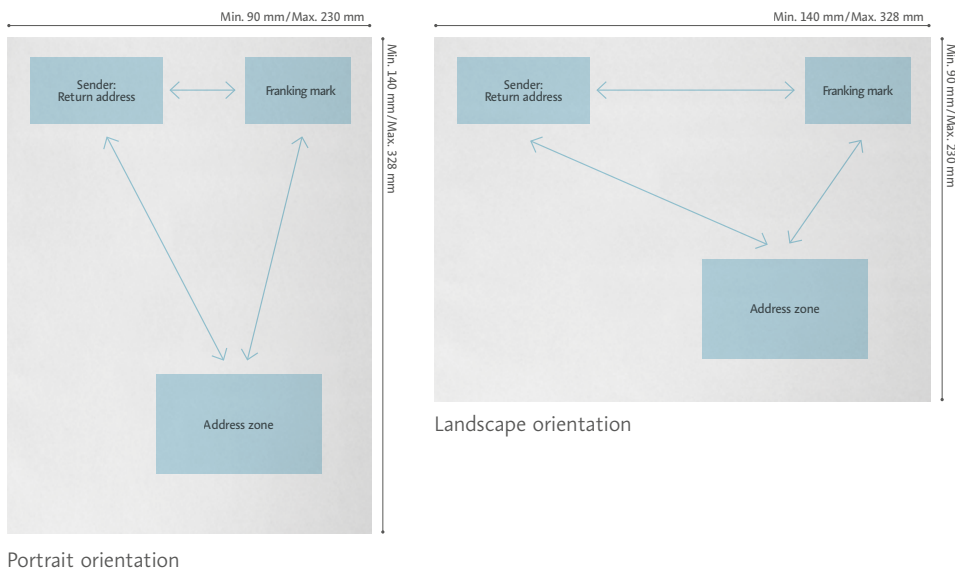

6.2.2 Use of an opaque white strip on the plastic film¹

The white strip must be:

- Ideally at least 85% opaque (ISO standard 1831), i.e. equivalent to ± 3 white layers.
- Free of any visible background text or graphics which may obscure the address.
- No more than 80 mm tall (ideally 60 - 80 mm).
- Always located in the upper part of the item in a landscape format, at least 10 mm below the upper edge of the envelope.

¹ The opaque strip MUST be white. Otherwise the mail item shall be considered a **Large+ Format** item.

2. Addressed mail > Creation - Large Format

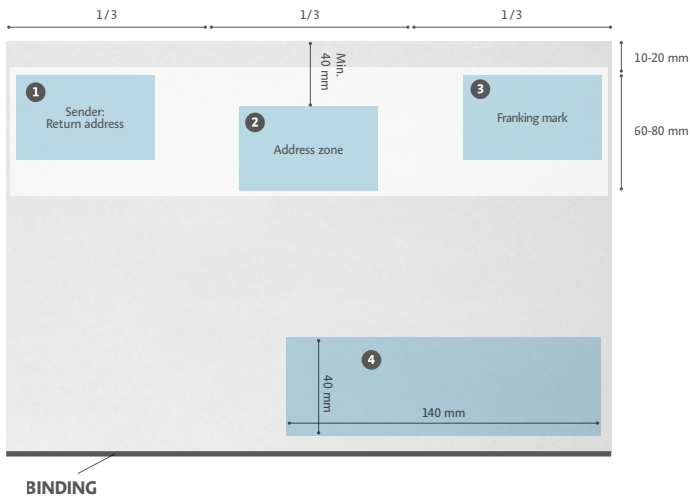

1 Return address zone

- Always preceded by the term 'Sender'.
- Positioned in the upper left third of the white strip and ideally on one line.
- For magazines and periodicals, etc. the title and publication frequency may also be printed here.
- Under no circumstances may the recipient address appear here.

2 Recipient address zone

- Positioned in the second third of the white strip
- Below the 'return address' and 'franking' zones
- At least 40 mm below the upper edge of the item

3 Franking zone

- Reserved for the franking mark (PP)
- For magazines and periodicals, etc. the name of the deposit office and the agreement number (P number) may also be printed here.

4 Control code zone

- It cannot contain an address or element that can be confused with an address because there is a risk that the white sticker with the index code ('ID tag') will cover it.

6.2.3 Use of a flyleaf under the plastic film

- The flyleaf must:
 - measure at least 90 x 140 mm
 - always be the same length (if landscape orientation) or the same width (if portrait orientation) as its contents. It must not be able to move around inside the film. Any item which does not comply with these criteria shall be considered a **Large+ Format** mail item.

Example of portrait orientation

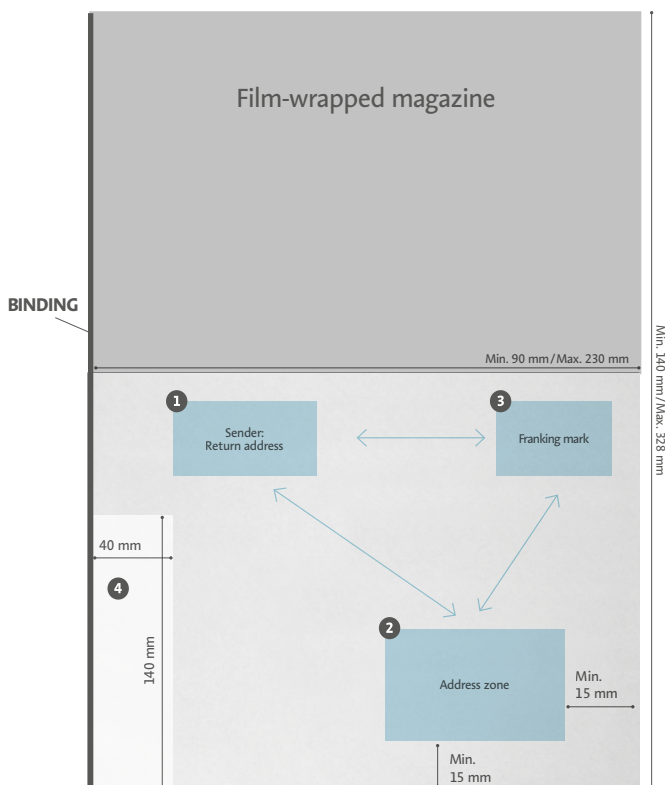

1 Return address zone

- Always preceded by the term 'Sender'.
- Positioned in the upper left corner at least 40 mm from the left edge (to avoid entering the code control zone) and ideally written on one line.
- For magazines and periodicals, etc. the title and publication frequency may also be printed here.

2 Recipient address zone

- Positioned at the lower right hand side at least 15 mm from the right and bottom edges.
- May not be positioned below the seal of the plastic film

3 Franking zone

- Reserved for the franking mark (PP)
- For magazines and periodicals, etc. the name of the deposit office and the agreement number (P number) may also be printed here

4 Control code zone

- It cannot contain an address or element that can be confused with an address because there is a risk that the white sticker with the index code ('ID tag') will cover it.

6.2.4 Recipient address on the reverse of the sending

The layout of the addresses (addressee and return) and the franking mark in **point 5.3.2** also apply.

new

6.3 Technical specifications for plastic film (bpost technical standards)¹

- Special instructions for ensuring suitably durable film and seal (mail items must not tear during handling).

| | LDPE ² | HDPE (or PP) ³ | BIO ⁴ |
|---|--|---------------------------|------------------|
| Thickness | 25µm | 20µm | 40µm |
| Pull resistance | - longitudinal min. 20 N/mm ² - transversal min. 15 N/mm ² | | |
| Static friction coefficient (after sealing and item against item) | 0.40 - 0.65 | | |
| Gliding friction coefficient | 0.35 - 0.60 | | |
| Electrostatic chargeability | < 2 kV | | |
| Length of edges | Delta between maximum packaging and container: - Vertical < 10 mm - Horizontal < 30 mm | | |
| Seam resistance | Tear resistance of all sealed points (especially printed areas, e.g. address strip): - at least 60% of film rupture resistance - longitudinal min. 4 N/15 mm ² - transversal min. 6 N/15 mm ² | | |
| Seal orientation for folds in landscape mode | Horizontal | | |
| Seal position in relation to address | Seal may not be positioned on the address block | | |
| Opacity of address material area | 85% as per ISO1831 standard | | |

- Antistatic film (no static charge generated during packing process) or treated such that mail items **cannot stick together**.
- The option for bpost to write on the opaque white strip (using a standard ballpoint pen) or stick a label on the film (e.g. change of address label or non-delivery notification). **Large Format** properties (e.g. shape, dimensions, weight, etc.) shall apply to the mail item in its entirety, including plastic film.

Any plastic-wrapped mail item which does not comply with these standards shall be considered a **Large+ Format** item.¹



For more information

If you have any queries about whether a specific mail item can be handled, contact our Service Center at **02 201 11 11** or send an email to **service.centre@bpost.be**.

¹ These are recommended standards for (non) addressed press items.

² Low Density Polyethylene.

³ High Density Polyethylene of Polypropylene.

⁴ If you use bio-plastic film under this standard, you should contact our specialists (**customer.operations@bpost.be**) to carry out the necessary tests for proper mechanisation of the product.

Creation - Large+ Format

1. Types of sendings

1.1 Square or rectangular

1.1.1 Dimensions, weight & thickness

A **Large+ Format**¹ item must comply fully with the criteria set out in the illustration below.

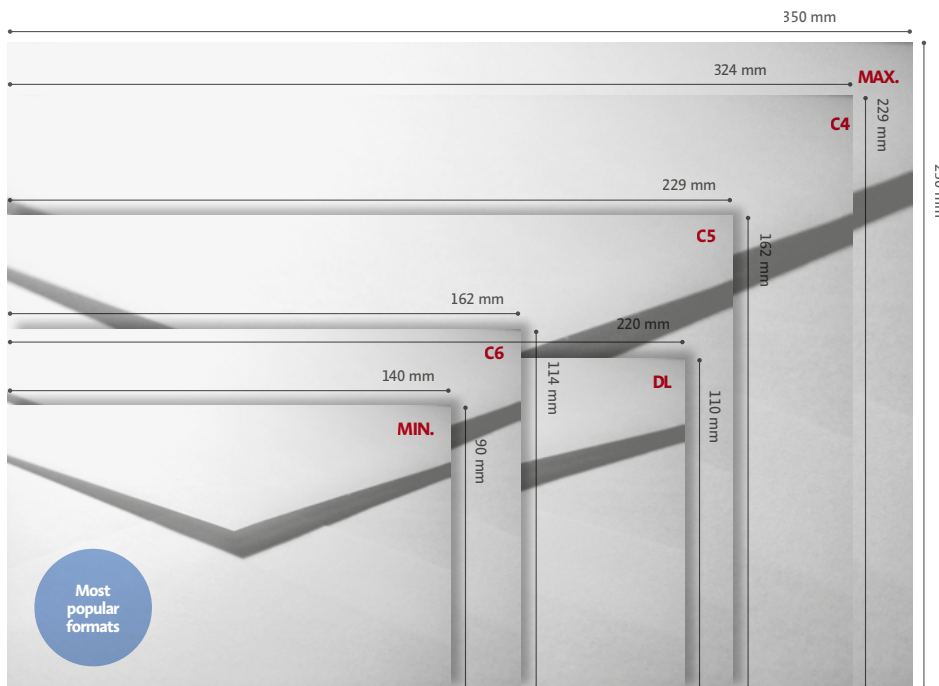

Minimum and maximum dimensions of **Large+ Format** mail items.

| | |
|--------------------------|---|
| Shape | Rectangular or square (with a minimum of 140 mm x 140 mm for square mail items) |
| Dimensions | Minimum (width) 90 x (length) 140 x (thickness) 0.15 mm |
| (inclusive of packaging) | Maximum (width) 230 x (length) 350 x (thickness) 30 mm |
| Weight | No recommended minimum |
| | Maximum 2 kg |
| Orientation | Landscape or portrait |

Extra Large Option

Possible for mail items between 230 and 265 mm wide (350 mm long and 30 mm thick). For such items, they must be flexible enough to comply with the dimensions of postal items able to pass through a letterbox.

Did you know?

Mail items >2 kg and/or in roll form are deemed to be parcels.



¹ Take care to conform to the postal regulations and the General Terms and Conditions of bpost, especially in respect of mail item contents. Bpost's General Terms and Conditions are available at www.bpost.be/site/fr/conditions.html.

1.2 Forms other than square or rectangular

1.2.1 Dimensions, weight & thickness

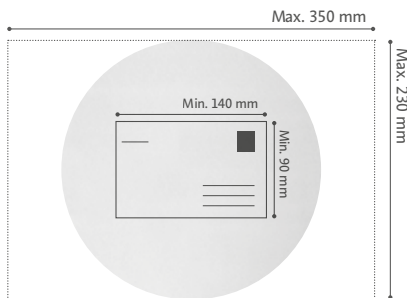

Circle

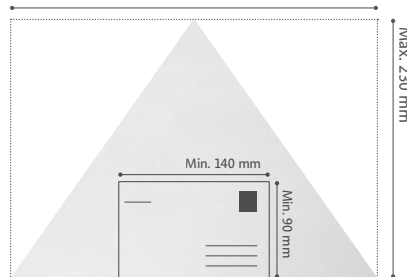

Triangle

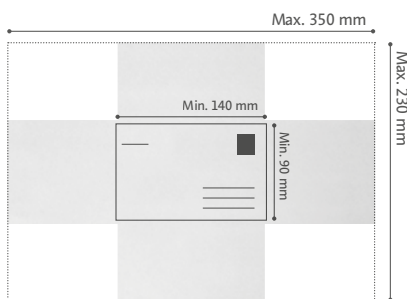

Cross

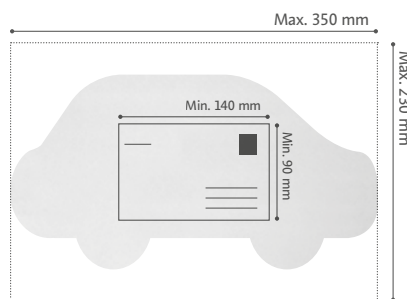

Other (example)

| | |
|-------------------|---|
| Shape | Any |
| Dimensions | Minimum (height) 90 x (length) 140 x (thickness) 0.15 mm (= size of rectangle reserved for addressing and franking area) |
| Weight | Maximum (height) 230 x (length) 350 x (thickness) 30 mm Maximum 2 kg |

1.2.2 Rounded and angular items

Use rounded edges and avoid sharp corners (i.e. < 90°) to avoid damage during the handling of the mail items.

2. Addressed mail > Creation - Large+ Format

1.2.3 Examples

Open/pierced mail items: diameter of the circle \leq 80 mm (see illustration below).

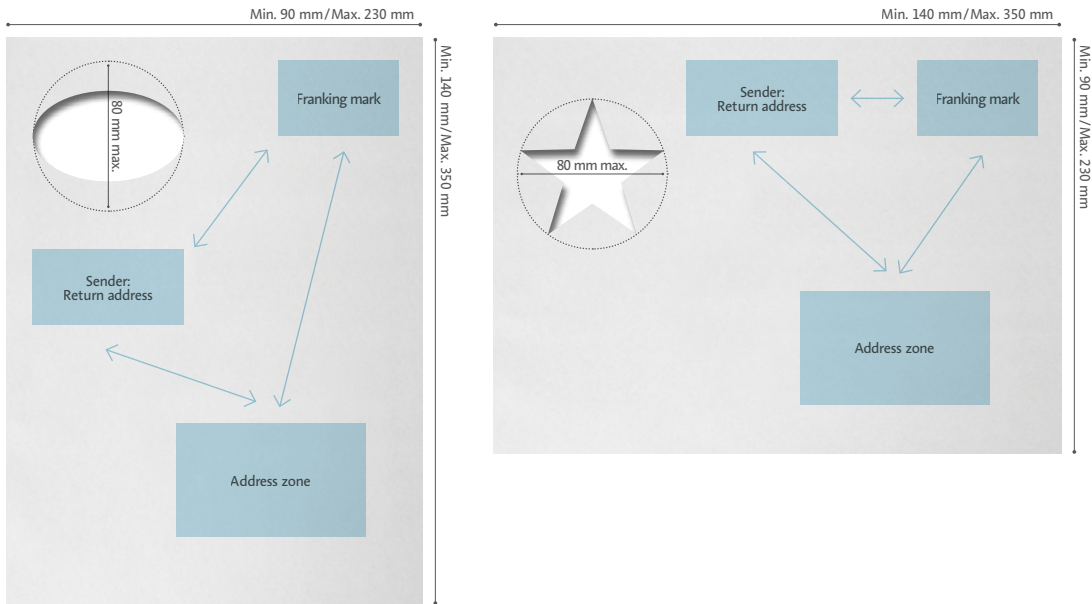

Solid forms

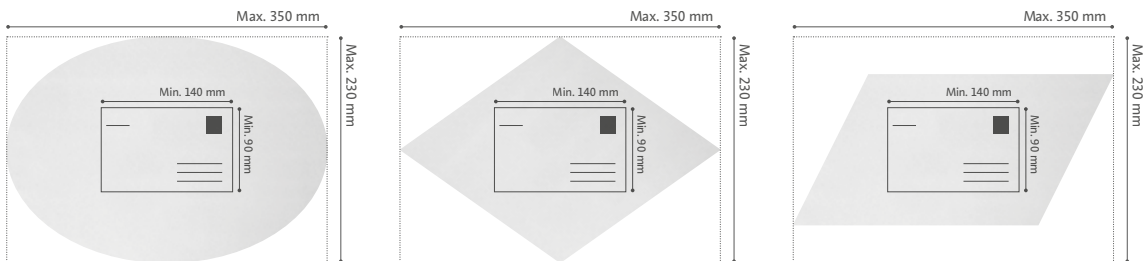



2. Characteristics

Large+ Format specifications (not an exhaustive list). **The following are permitted:**



- rectangular, square, 'almost square' format (item width:length ratio <1.2), or non-rectangular and non-square items (e.g. oval, round, etc.)
- portrait or landscape orientation (address box parallel to short side of the item)
- rigid and/or metallized¹ and/or cardboard mail items
- mail items containing a rigid object
- mail items open on 1 side, or more
- items bearing 1 or more repositionable stickers
- items wrapped in plastic film (need not be bpost-standard-compliant)
- padded and/or bubble-wrap envelopes
- translucent, bright, varnished, glazed or glossy envelopes
- small format items which do not meet the presentation criteria for **Small Format** mail items
- metallic closures (e.g. staples, paperclips, eyelets, etc.)
- items containing liquids
- mail items with partially glued parts (e.g. cardboard, cards, envelopes, etc.)
- open or pierced mail items (e.g. windows not closed by transparent film)

3. Visual presentation of your mail items

Definitions of the despatch and visual zones covered in the section entitled **Creation - Large Format (Points 2.1, 2.2 and 2.3 of point 2. Visual presentation of your mail items)** also apply to **Large+ items**. The only difference being: **the maximum permitted length of the longest side is 350 mm.**

¹ For magnetic items, regardless of their size, pre-approval is required via this address: customer.operations@bpost.be.



4. Sealing methods for mail items

Five options for your Large+ Format mail items

- placed in a paper or cardboard envelope
- open mail items (sent as a self-mailer - see **Point 5.1** - or a postcard - see **Point 5.2**)
- items wrapped in plastic film (need not be bpost technical standards compliant)
- sealed with a strip or a self-adhesive system
- sealed by stamping or tear-off strip

Sealing criteria

- mail item in an envelope, cardboard or plastic cover: the closure (and any flap) must be completely sealed on all 4 sides such that they cannot open or tear during handling
- sealing adhesive must not come into contact with any other mail item
- contents of the mail item must not come out of the envelope, nor must it be possible for them to do so
- exterior sealing strip must be robust (thickness ≥ 0.2 mm) and suitable for the content
- staples, paperclips or metallic eyelets are permitted, in any position
- envelopes with multiple attachment points are permitted

5. Paper characteristics

- Item must be sufficiently robust.
- Paper weight:
 - ≥ 140 g/m² (mail items comprising a single layer of paper, e.g. postcard)
 - ≥ 70 g/m² (mail items comprising several layers of paper, e.g. envelope or self-mailer)

6. Features of open mail items

(self-mailers, postcards and mail items with binding)

6.1 Self-mailers

A self-mailer is an addressed and franked pre-printed folder. It can be sent in the mail without an envelope (or plastic film).

Self-mailers are deemed **Large+ Format** mail items, providing they:

- comply with the definition of **Large+ Format** and/or
- share one or more **Large+ Format** characteristics
- are sealed using staples, paperclips and/or metallic eyelets



2. Addressed mail > Creation - Large+ Format

6.1.1 Examples of sealing methods

See the section on **Creation - Large Format 5.1.1**.

6.2 Postcards

Postcards which comply with some or all of the defining characteristics of **Large+ Format** mail items (e.g. weight, dimensions, etc.) are deemed **Large+ Format** mail items.

The layout specifications in the **chapter Creation - Large Format, point 5.2** also apply to **Large+ Format** mail items as recommendations.

6.3 Bound mail items without envelope or wrapper

Mail items consisting of several bound pages (not placed in an envelope or in plastic film) follow the same layout rules for the front and back of the items as non-bound items (see **Point 2 of Visual presentation of your mail items in the section entitled Creation - Large Format**, excluding the maximum longest side length, which is 350 mm for **Large+ Format** items).

6.3.1 Using a white label for the recipient address

See the section entitled **Creation - Large Format**.

6.3.2 Recipient address on the back of the mail item

See the section entitled **Creation - Large Format**.

Did you know?

If you have any queries about whether a self-mailer, postcard or open mail item can be handled, contact our Service Centre on **02 201 11 11** or send an email to **servicecentre@bpost.be**.





7. Specifications for mail items wrapped in plastic film

The specifications which apply to the printing of the recipient's address on and beneath plastic film, as set out in the section entitled **Creation - Large Format, Point 6**, are also guidelines for **Large+ Format** items.

7.1 Positioning of the recipient address, return address and the franking mark

Guidelines regarding positioning of the recipient address, return address and the franking mark as set out in the section entitled **Creation - Large Format, Point 6.2** also apply to **Large+ Format** mail items.

For **Large+ Format** items, the strip for the recipient address, return address and franking mark need not be white.

7.2 Technical specifications for plastic film

The technical specifications for plastic film as set out in the section entitled **Creation - Large Format, Point 6.3** need not be bpost-standard-compliant for **Large+ Format** mail items.



Mail Item Format Overview

Format Summary Table

| Title | Category | Small | Large | Large+ |
|----------------------------------|---|--------------------------------------|--|--|
| Dimensions, weight and thickness | Rectangular shape | Yes | Yes | Free (e.g. square, rectangular, oval, triangle, ...) |
| | Square shape | No | Yes | |
| | Minimum dimensions | 90 x 140 x 0.15 mm | | |
| | Max. dimensions | 165 x 245 x 5 mm | 230 x 328 x 10 mm Thickness variability: 4 mm with max. height of 10 mm | 230 x 350 x 30 mm Extra Large Option: up to 265 x 350 x 30 mm |
| | Min. weight | 2 g | 2 g | No recommended minimum |
| | Max. weight | 50 g | 350 g | 2 kg (mail items exceeding this are deemed to be parcels) |
| | Length:width ratio | ≥1.20 | No restrictions | No restrictions Open or pierced items possible |
| | Orientation | Landscape | Landscape or Portrait | Any |
| Address box | Always parallel to the longest side | May be parallel to the shortest side | May be parallel to the shortest side | |
| Characteristics | Rigid mail items | No | <ul style="list-style-type: none"> Rigidity standards: lengthwise rigidity: item should be flexible enough to wrap around a 900 mm-diameter cylinder (along the bound edge, if there is one) Flexibility standards: the item should not bend more than 90 mm above the horizontal. For further guidance : see section entitled Large Format 1.2 Characteristics - Flexibility and Rigidity Standards | No restrictions Open or pierced items possible |
| | Metallized mail items | No | Yes, so long as they comply with weight, thickness and rigidity/flexibility conditions | Yes |
| | Cardboard mail items | No | Yes, so long as they comply with thickness and rigidity/flexibility conditions | Yes |
| | Insert or rigid object | No | Yes, if affixed in the mail item, and so long as they comply with thickness and rigidity/flexibility conditions | Yes |
| | Open on 1 side, or more | No (apart from self-mailers) | Yes | Yes |
| | Items bearing 1 or more repositionable stickers | No | Yes | Yes |
| | Items wrapped in plastic film | No | bpost standards | No standards apply |
| | Padded and/or bubble-wrap envelopes | No | Yes, but must comply with stipulations regarding thickness and rigidity/flexibility | Yes |
| | Translucent, bright, varnished, glazed or glossy envelopes | No | Yes | Yes |
| | Ratio of length (longest side) / width (shortest side) < 1.2 (square or virtually square shape) | No | Permitted | Permitted |
| | Non-rectangular and non-square items | No | No | Permitted |
| | Open or pierced mail items (e.g. windows not closed by transparent film) | No | No | Permitted |
| | Mail items with partially glued parts (e.g. cardboard, cards, envelopes etc.) | No | No | Yes |
| | Items containing liquids | No | No | Yes |



2. Addressed mail > Format Summary Table

| Title | Category | Small | Large | Large+ |
|---|-----------------------------------|--|--|--|
| Visual presentation of the mail items | Address printed in semi-free zone | No address printed in semi-free zone | Permitted | Permitted |
| | Advertising window | <p>Must be closed with a transparent film window.</p> <p>Mail items with no sender address window but containing at least one advertising window on the front will automatically be deemed Large or Large+ Format items.</p> <p>If the advertising window on the front has one or more elements that could be confused with an address, the item shall be deemed a Large or Large+ Format mail item.</p> | Must be closed with a transparent film window. | May be closed with a transparent film window or may be an open item. |
| | Sealing | <p>Sealing criteria</p> <ul style="list-style-type: none"> in envelopes: item (and any flap) must be completely sealed on all 4 sides such that they cannot open or tear during handling sealing adhesive must not come into contact with any other mail item contents of the mail item must not come out of the envelope, nor must it be possible for them to do so exterior sealing strip must be robust (thickness > 0.2 mm) and suitable for the content staples, paperclips or metallic eyelets must not be used to close the mail item | <p>Applicable to Large items</p> <ul style="list-style-type: none"> placed in a paper or cardboard envelope sent without an envelope or wrapper (as a self-mailer - see Point 5.1 - or a postcard - see Point 5.2) items wrapped in plastic film (if bpost-standard-compliant) sealed with a strip or a self-adhesive system sealed by stamping or tear-off strip <p>Sealing criteria</p> <ul style="list-style-type: none"> in an envelope, cardboard or plastic film cover: item (and any flap) must be completely sealed on all 4 sides such that they cannot open or tear during handling sealing adhesive must not come into contact with any other mail item contents of the mail item must not come out of the envelope, nor must it be possible for them to do so exterior sealing strip must be robust (thickness > 0.2 mm) and suitable for the content staples permitted in the case of an open magazine, if staples are attached to the binding no envelopes with multiple attachment points (envelopes for thicker items and which can be folded) | Same criteria as for Large Format , plus the following approved criteria: <ul style="list-style-type: none"> staples, paperclips or metallic eyelets, in any position envelopes with multiple attachment points |
| Paper | Paper characteristics | <p>Envelopes made of opaque matte paper</p> <p>Flexible mail item (must be flexible enough to wrap around a cylinder of 21 cm circumference, e.g. 33 cl can)</p> | <p>Translucent, bright, varnished, glazed or glossy envelopes</p> <p>Flexibility and Rigidity: see section entitled: Large Format 1.2 Characteristics - Flexibility and Rigidity Standards</p> | <p>Translucent, bright, varnished, glazed or glossy envelopes</p> <p>Sufficiently robust item</p> |
| Self-mailers | | <p>Robust closure (such that it cannot open or tear during handling).</p> <p>3 of the 4 sides must be completely sealed, including the right-hand side and the underside of the mail item (and ideally all 4 corners).</p> | The 2 opposing shorter edges of the items may not only be sealed | <p>Staples, paperclips or metallic eyelets on the outside of self-mailers</p> <p>The 2 smaller edges may be sealed only</p> |
| Postcards | | Criteria and characteristics of Small Format items | Criteria and characteristics of Large Format items | Criteria and characteristics of Large+ Format items |
| Items wrapped in plastic film | | Not permitted | Permitted | Permitted |
| | Opaque white strip | Not permitted | The opaque strip must be white. If colour => Large+ | Permitted : <ul style="list-style-type: none"> Strip other than white in colour Glossy plastic without a white strip Little or no contrast between address colour and plastic colour |
| Technical specifications for plastic film | | Non applicable | bpost-standards-compliant | No restrictions |

Mail ID Technology

1. Definition and scope of Mail ID Technology

Mail ID technology is a method of transmitting your address data to bpost before processing your mail items deposited under contract, and involves 2 parts:

- An electronic address file exchange system with bpost.
- The printing of unique Mail ID barcodes (and in some instances a sequence reference code) in each mail item's address box.

To use this technology, prior certification from bpost for each mail item type is required.

Advantages

- More efficient mail item sorting and a better-quality service.
- The quality of addresses in your database improves as you get feedback on non-recognised (non-deliverable) addresses.

Scope

- **Small Format**
- **Large Format**
- **Large+ Format**

Deposit terms

- Depositing of 'Letters' or 'Direct Mail' under contract with bpost.
- Use of the e-Masspost app.
- Full compliance with all technical specifications set out in the **Data Exchange Technical Guide** (available via customer.operations@bpost.be)
- Certification for the type of mail item involved.

For **Large** and **Large+ Format** items sorted by Round and sequence, Mail ID barcodes must be printed along with a sequence reference.



2. Certification

Specific certification for each type of product

- **Small Format Mail ID**
- **Large(+)** **Format Mail ID** in an envelope
- **Large(+)** **Format Mail ID** wrapped in plastic film
- **Large(+)** **Format** on plastic (printing on white band)
- **RSV3**

The certification process validates your technical parameters to enable the exchange of files with bpost (connection, syntax, etc.) and to guarantee that barcodes and sequence reference codes printed on your mail items can be recognised correctly. All information on the certification process can be found in the **Data Exchange Technical Guide** which is available via customer.operations@bpost.be.



3. Electronic address file exchange system

Mail ID technology is based on an electronic address file exchange system.

For each mail item, the address file must contain

- The address: street, house number, box number (where appropriate), postcode and area.
- The relevant barcode for each address. This is a unique number allocated per item and cannot be reused within 30 calendar days of the file's date of dispatch.
Optional: at your request, a bar code will be generated for you by bpost and included in the response file.
- Where appropriate, the last name and first name of the recipient (or if the recipient is a legal entity, its company name).

To ensure that your mail items are processed in the most efficient manner possible, data in the address file may be amended in order to add information which may ensure better handling (e.g. weight, dimensions, return address, etc.).



More information on file structure and syntax can be found in the **Data Exchange Technical Guide** which is available upon request from customer.operations@bpost.be.

3.1 The answer file (Response)

bpost will process and analyse the addresses in your file and will then send you a response file containing:

- the recognition rate of your addresses
- a list of addresses that are only partially recognised or unrecognised by bpost (to help you improve your database)
- optional sorting information (sorting plan) and (as an option) the sorting order to be followed (see the content of these concepts in points **3.1.1** and **3.1.2**)
- the sequence reference codes to be printed on the mail items (for Round and sequence)
- optional mail ID barcodes

An address recognition rate of 96% is required to use mail ID technology for your deposit.
An address recognition rate of 98% or more will entitle you to a Data Quality Discount.



new

Did you know?

If the electronic file for your deposit also contains the last name and first name of the recipient or the company name, you may be eligible for a Mail ID+ discount.





The types of sorting information and reference codes that appear in the answer file are:

new

3.1.1 Sorting plan Small V1 or V2

This sorting plan consists of 3 elements:

- a sorting centre (e.g. A for Antwerp), and, for V2, followed by the distribution zone (a or b)¹
- a wave number (e.g. W1)
- a sorting plan number (e.g. E1)

Example: A-W1-E1 (V1) or Aa-W1-E1 (V2)

new

3.1.2 Round and sequence sorting V3²

The Round and sequence sorting V3 reference, comprises 2 elements:

- the notion of sorting plan for **Large Format** or **Large+ Format**
- the Sequence reference code

a The Large Format and Large+ Format sorting plan rule

This rule is represented by 3 elements:

- a sorting center (E.g. C for Charleroi), followed by the distribution zone (a or b)¹
- a machine number (e.g. M1)
- a wave number (e.g. W1)

Example of Round and sequence V3 reference: Ca-M1-W1/7500-Reg-045/25 or Cb-M1-W1/7500-Reg-045/25

b The Sequence reference code

The sequence reference code follows the sorting plan **Large(+)** Format and shall contain at least the following information:

- the postcode of the distribution office
- the type and number of the round
- the sequence number

E.g. 1000-Reg - 012/1

- 1000 = postcode of the distribution office
- Reg - 012 = type and number of the round
- /1 = sequence number

Example of Round and sequence V3 reference: Ca-M1-W1/7500-Reg-045/25 or Cb-M1-W1/7500-Reg-045/25

For addresses that are only partially recognised or unrecognised by bpost, the sequence reference code will be replaced by one of the following codes:

- '0299': distribution office not found
- 'No-Rte': round not found
- '99999': sequence number not found

Depending on the code generated, you must prepare the mail items as follows:

- response '0299': to be placed in overflow trays (refer only to: **Preparation of your mail items - Packaging, point 4**)
- response 'No-Rte': to be placed at the top of the bundle for the relevant distribution office
- response '99999': to be placed at the end of the relevant round

¹ For the term "zone", please refer to this section, chapter **Sorting options**.

² The sorting Round and sequence V2 version remains possible until 30/06/2020.

4. Printing the Mail ID barcode and the sequence reference code

4.1 Mail ID barcodes

In order to ensure optimal readability of barcodes by the sorting machine:

- Barcodes should be printed above the recipient address box, in the zone for the recipient's address, at maximum of 1 cm from the 1st line of the address. For more addressing information, please see **section 1 Addressing and Franking, Chapter 1 Addressing, point 1.**
- The barcode is set up and printed in accordance with the specifications set out in the **Data Exchange Technical Guide.**
- The address must be printed (handwritten addresses are not acceptable).

Example: technical dimensions of address box and zone for the address box with address, Mail ID, sequence reference code RSV3 and customer references.

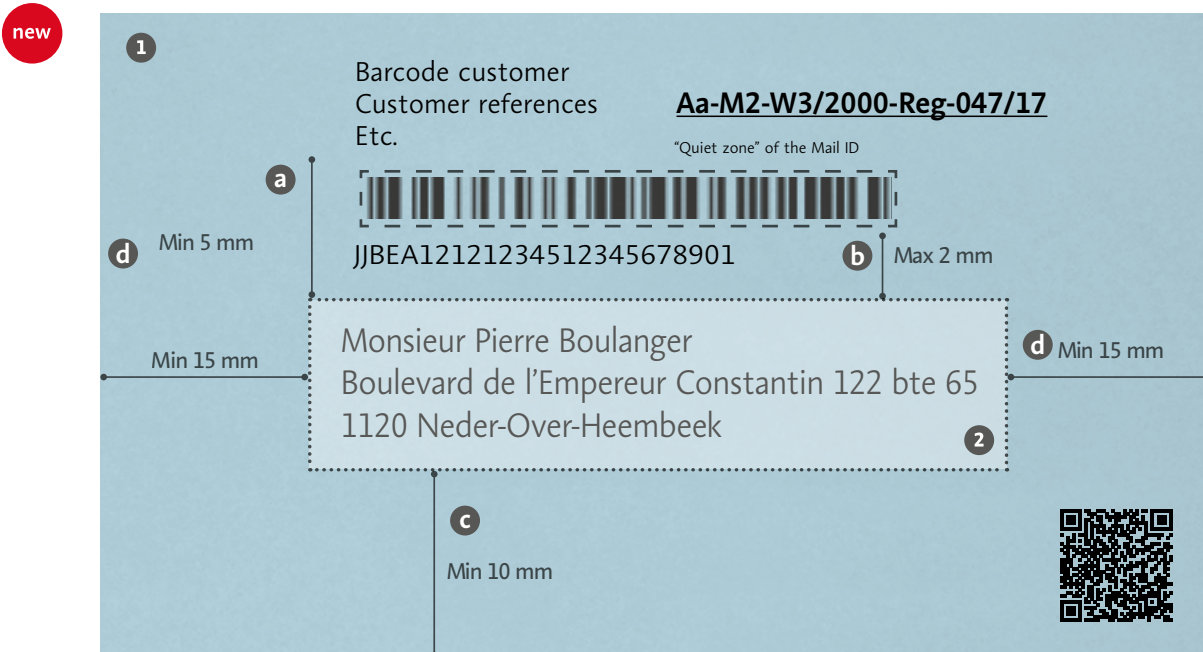

❶ Zone for the recipient's address

❷ Address box

❶ 5mm between the barcodes and all other information on the same line

❷ 2 mm space above and below the barcodes

❸ 10 mm space between the virtual address box and any other information (except Mail ID barcodes)

❹ 15 mm between the virtual address box and the left (or right) side of the mail item

For mail items wrapped in plastic film, the Mail ID barcode may not be directly printed on the plastic (except registered product that meets specific certifications).



Ideally, the address and Mail ID barcode will be printed:

- on plain paper (of the same width or length as the mail item) and inserted inside the plastic such that it remains securely in place.
There must be nothing on the front of the item which might be confused with the recipient address. Please comply with the layout shown for the address zone and franking area as shown in **point 6.2.3 of this section, Large Format Chapter**.
Ensure that the Mail ID barcode is not positioned beneath the seal of the plastic film.
- on an opaque white label, affixed to the plastic film.

For mail items with window and MailID barcodes on a white label stuck on the envelope, this label must be placed on the window, at maximum 1 cm above the address, and must not hide this address:

However, it can be affixed outside or on the edge of the window provided that it has been bpost-tested (contact: customer.operations@bpost.be).

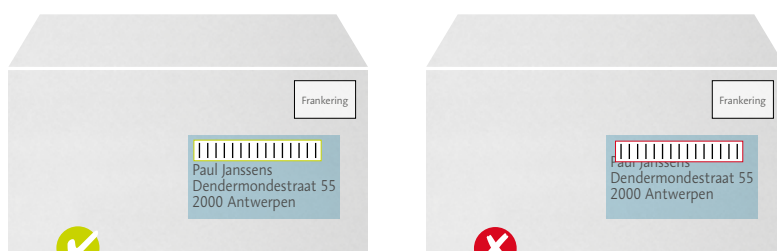

In the window at maximum 1 cm above the address

Do not hide the address



4.2 RSV3 sequence reference¹

When depositing **Large** or **Large+ Format** items sorted by Round and by sequence, you must print a Mail ID barcode and sequence reference code on every mail item.

In order to ensure optimal readability of barcodes by the sorting machine

- the sequence reference should be printed in the zone for the recipient's address above the address box and to the right, at maximum 1 cm apart
- sequence reference font size \geq recipient address font size
- the sequence reference should be bold and/or underlined
- the address box layout must comply with the **Large** or **Large+ Format** mail item rules
- the various parts of the sequence reference should be of correct order and structure
- the Mail ID barcode should be positioned at maximum 1 cm above the 1st line of the address and the sequence reference above the barcode (distance \geq 2 mm)
- the address must be printed (handwritten addresses are not acceptable).

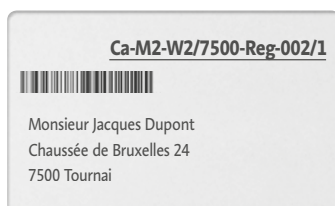

¹ Sorting Round and sequence V2 version remains possible until 30/06/2020.

Other possible alternatives

The Mail ID barcode positioned above the address, and the sequence reference code positioned on the same line as the Mail ID barcodes, to its right (at least 5 mm away).



Sequence reference code positioned above the Mail ID barcode, allowing 2 mm between each code.



5. Mail ID file addressing rules

Following the addressing rules will enable the maximum recognition rate for your electronic addresses by bpost.

Full details of these rules are given in the **Data Exchange Technical Guide**, available via customer.operations@bpost.be. 

For details on printing addresses on your mail items, see the **Creation chapters** on **Small**, **Large** and **Large+ Format** items.

All the regulations set out in this section are necessary to ensure that Mail ID runs smoothly. 

Failure to comply with any of these rules on an ad hoc basis will result in the reclassification of the mail items concerned at the corresponding rate without MID or in the application of a tariff supplement.

Failure to comply with these rules on a recurrent basis will result in the withdrawal of the MID certification granted (withdrawal of access to Mail ID tariff).



Preparing your mail items - Packaging

1. Packaging types available for your mail items

All the packaging types shown below can be supplied by bpost with its prior agreement. You can order containers, Palletboxes and trays from your (Hyper) Masspost Center.

1.1 Trays Containers

Trays containers enable and facilitate the transport of blue trays (see point 1.1.1 of this chapter).

- volume considered sufficient for a direct container: 10 trays
- gross weight: maximum 500 kg (including container)
- capacity: maximum 24 trays

A direct container is a container used for

- a sorting plan or
- distribution office or
- sorting sector or
- sorting center

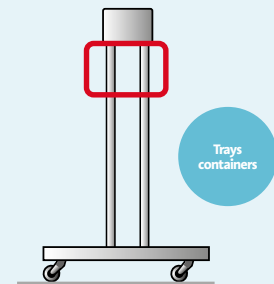

1.1.1 Blue trays

Blue trays are bpost's preferred presentation means for

- unsorted mail items
- sorted mail items (by postcode, by sorting sector and by distribution office)
- **Small Format** mail items sorted by sorting plan V1 or V2*
- "Pilot Postcards" type mail items

They may not contain any bundles.

Every tray has

- a space for affixing a label (105 mm long x 101.6 mm wide) along its length
- a barcode

Blue tray technical specifications

- Length: 470 mm
- Width: 310 mm
- Height: 230 mm
- Empty weight: 1.371 kg
- Maximum weight (tray & contents): 12 kg

* For more information, see the chapter on **Preparing your mail items - Sorting options**.





2. Addressed mail > Preparing your mail items - Packaging

1.1.2 How to deposit mail items in blue trays

- All mail items must be packed in the same direction (with addresses always facing the same way).
- Mail items must not extend above the tray handles (to ensure that mail items are not damaged when trays are stacked).
- The trays may only contain non-bundled mail items (do not use string etc. to join mail items together).

a Small Format mail items



- Standing up in the tray.
- Franking mark in the upper right-hand corner opposite the space for the label.
- Only C6 format mail items (i.e. one sheet of A4 folded into 4) can be packed in the tray in two rows.

b Large and Large+ Format mail items

Landscape mode



- Flat in the tray.
- With the franking mark clearly visible, on the opposite side from the space for the label.
- Blue tray contents can be divided in 2 (lengthwise), so that you have two stacks of mail items (e.g. two stacks of A4 folded in 2).

Portrait mode



Did you know?

For sorted mail items, the use of overflow reduces your logistics costs, by avoiding the transport of trays which are not full.



Always ensure the correct orientation of the franking mark for **Small, Large and Large+ Format** items to render them legible to the sorting machine. Failure to comply with this requirement means a self-adhesive sticker or notice may be affixed to the item, potentially concealing important customer information (advertisements, reference codes, logos, etc.).





2. Addressed mail > Preparing your mail items - Packaging

1.2 Restmail Containers

Gross weight: maximum 400 kg (including container).



For more information on the rules on sorting plans, distribution offices, sorting sectors or sorting centers, see the chapter on **Preparing your mail items - Sorting options**.



1.2.1 Bundling mail items - bundle characteristics

| | |
|------------------------|---|
| Thickness | Minimum 3 cm Maximum 12 cm |
| Weight | Maximum 7 kg |
| Bundling | Securely tied in a cross (to avoid damage to the mail items or bundles coming apart during handling or transport) |
| Bundle material | Prefer mail items placed in the same direction Plastic straps are preferred |
| Durability | Bundles must remain intact after five drop tests (from a height of 1 m onto a concrete floor) and the gap between the strapping and the contents must not exceed 0.5 cm (under their own weight). |

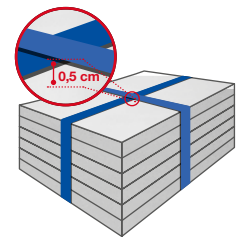

Use of elastic or metallic straps is prohibited (materials are incompatible with the automated transport and sorting equipment).
Bundles may not be placed in blue trays and/or cardboard boxes.
Bundles must be placed in their containers or pallets all facing the same way.



For mail items >1kg, avoid bundles (not enough for the maximum allowed weight, i.e 7kg): they can be placed directly on pallets.

2. Addressed mail > Preparing your mail items - Packaging

1.2.2 The two bundle types

a Direct bundles

- The recipient address must appear on at least the first mail item in the bundle.
- The mail items of each bundle must be arranged by street (in alphabetical order).
- All mail items in a single bundle must be for the same distribution office. (Please refer to **point 5 of this chapter, Important Definitions**).

Addresses are only visible on one side of the bundle

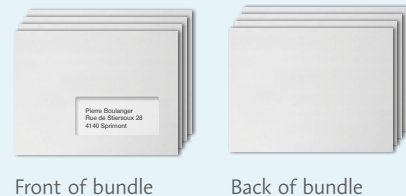

Front of bundle

Back of bundle

new

b Direct bundle by Round and sequence V3¹⁻²

- These comply with the direct bundle conditions.
- Mail items in a single bundle are for one or more mail rounds under the same distribution office.
- For the composition of the bundles, please follow the sorting/breaking sequence according to the instructions of the bpost response file.
- Each mail item must bear its own sequence reference³, as well as the **Large** and **Large+ Format** sorting plan rule.

This sorting plan is made up of 3 parts:

- a sorting center (e.g. C for Charleroi) with a distribution zone (a or b)
- a machine number (e.g. M1)
- a wave number (e.g. W1)

Example: Cb-M1-W1/7500 - Reg-045/25

- The sequence reference printed on the mail items must comply with the addressing rules (see **point 4, Mail ID Technology chapter**).

Addresses are only visible on one side of the bundle (as for direct bundles)

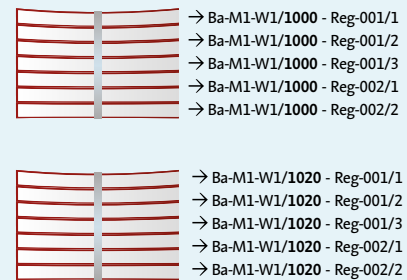

Direct bundle by Round and sequence = 1 distribution office

If there are too many mail items for a single bundle intended for a given distribution office, consecutive bundles should be made: each successive bundle continues on from the preceding bundle in terms of rounds and sequences.



¹ Sorting Round and sequence V2 version remains applicable until 30/06/2020.

² For the definition of the different sorting options, please refer to **section 2, Addressed Mail - Preparing your mail items - Sorting options**.

³ The sequence reference states the postcode of the distribution office, the type and number of the mail round and the sequence number (i.e. order in which the mail items will be delivered during the round) for each address. E.g. the postcode of the distribution office = 1000, the type and number of the round = Reg-012, the sequence number (order of the address in the round) = 1. Here the sequence reference is: 1000 - Reg-002/1.



2. Addressed mail > Preparing your mail items - Packaging

1.3 Palletbox Mail

new

Packaging for your **Large** and **Large+ Format** mecanizable mail items sorted by Round & sequence V3

Advantages

- Ergonomic and easy to use
- Foldable and stackable (space-saving)
- Your product no longer requires bundling (lower costs, less preparation time and less damage)
- Makes packaging by complete sorting plan easier for pre-sorted items
- Traceable via barcode

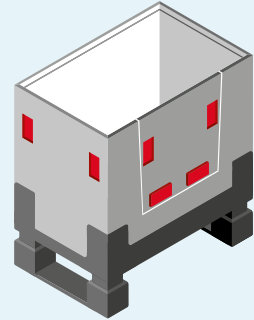

Technical data

| | |
|-------------------------|--------------------|
| External dimensions | 800 x 600 x 770 mm |
| Internal dimensions | 744 x 544 X 645 mm |
| Height folded Palletbox | 321 mm |
| Weight | 23 kg |
| Carrying capacity | maximum 250 kg |

Follow the rules below for placing your mail items in the Palletbox Mail

The pallet box **must be filled to a minimum of 80%**. You may use paper to fill in empty spaces. Other materials are not allowed. Blue trays are not accepted.

Calculate the optimal filling



To calculate how best to fill the Palletbox, you can use the Palletbox tool. The tool is available via the e-MSP application at www.bpost.be/e-masspost.

You can calculate the **optimal filling** by entering the following data:

- **Length, width** and thickness of the shipment
- **Weight** of the consignment

The tool displays the **number** of shipments per sorting plan and per pallet box. With this information you can start filling up the Palletbox



2. Addressed mail > Preparing your mail items - Packaging

How to fill in the Palletbox Mail ?

1. You have to fill in the Palletbox Mail using a unique sorting plan that you receive from bpost. The sorting plans are drawn up on the basis of your uploaded address file.
2. You can also combine several sorting plans in one Palletbox Mail, in which case we ask you to
 - laying the different sorting plans in horizontal layers on top of each other.
 - to separate the different sorting plans by means of a separator sheet indicating the new sorting plans
 - place the horizontal layers in descending order, according to the file you received from bpost

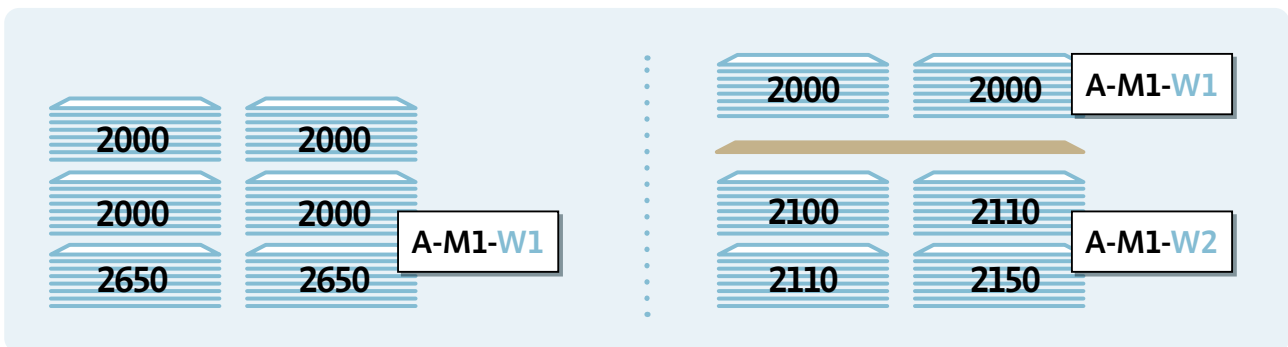

Please respect the correct sequence and the correct filling method per format.



Place horizontal items so that the PP/PB number is opposite the long side with the pallet label.

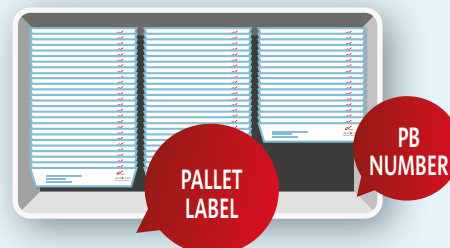

For upright items, ensure that the PP/PB number is facing upwards and opposite the long side of the pallet label.



2. Addressed mail > Preparing your mail items - Packaging

Storage according to descending sequence for horizontal mail items¹



C5 format

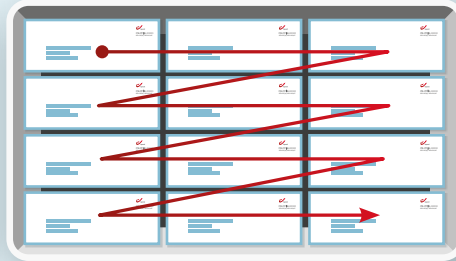

US format



C4 format



A4 format

If there is a space of 10 cm on the sides, you can fill this space with upright mail items.

Storage according to descending sequence for upright mail items

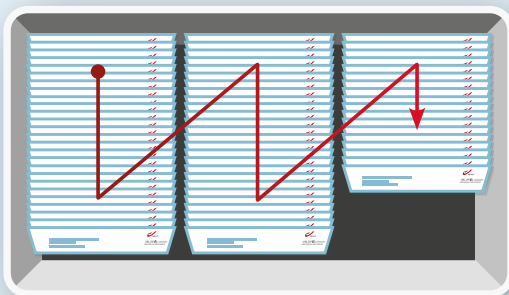

US format

Interested?

If you would like to know more about how to use them, please contact customer.operations@bpost.be.



We also refer you to the Palletbox Mail poster at www.bpost.be/masspost, tab 4 Conditioning and Sorting and to the section **Preparing your mail items - Sorting options** of this section.

¹ See definition of sequences in **chapter Sorting options point 5**.

1.4 Pallets

- Gross weight: maximum 700 kg (to a maximum height of 1.6 m).
- A filling with a minimum volume of 200 kg or a minimum height of 80 cm is desired. If you do not reach this minimum for a sorted depot, organise a grouping at a lower sorting level, as described in this section - Sort options, **§ 4 and 5**.

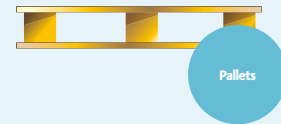

Safety instructions

To avoid your mail items falling during transport or handling, you must

- ensure blue trays and bundles are stacked correctly and securely on the pallets
- wrap pallets with their contents in plastic film
- use of metallic strips is prohibited



For more information on bundles, see **point 1.2.1**.



Did you know?

Cardboard pallet boxes can also be used to pack mail items, but are reserved for international customers only.





2. Addressed mail > Preparing your mail items - Packaging

1.5 Closed cardboard boxes

This type of packaging is an alternative to the conditioning in blue trays and is for international customers' use only

- boxes may be only used once they are at least half full
- weight: maximum 7 kg (including box weight)
- box dimensions must be slightly larger than mail item dimensions
- it may not contain any bundles.
- boxes must be properly closed (to avoid mail items falling out during transport or handling at the sorting center)
- each box must be labelled (showing the appropriate notices to indicate sorting type, along with the words 'À distribuer/Te bedelen').
For more information, see the **chapter on Preparing your mail items - Sorting options**.

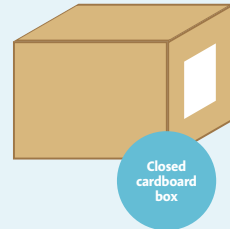



new

2. Overflow

Overflow is the term for the items which are left over after sorting and packaging, and which cannot be packed correctly as trays or bundles contain less than the minimum packing requirement.

These surplus items must be placed in blue trays and clearly labelled (see **point 4 of this chapter**).

- Overflow volume = no more than 7.5% of the total deposit volume.
- If the overflow percentage exceeds 7.5%, these unsorted mail items will be calculated as follows:

$$\text{Number of overflow pieces} = \frac{\text{Total weight of overflow}}{\text{Average weight of a mail item}} \quad (\text{You will be invoiced a supplement for each overflow piece.})$$

- If the overflow percentage exceeds 20%, these mail items will be deemed to be a separate unsorted deposit and will be invoiced as such.

More information on the processing of the overflow can be found in this chapter Sorting options in points **4.2.4 (Small Format)** and **5.4 (Large Format)**.





3. How to label appropriately for different packaging

The model below shows all the information to be included on each label.

3.1 Label dimensions

3.1.1 Blue trays and cardboard boxes

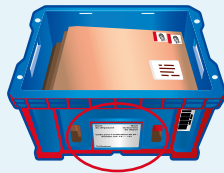

For trays: 101.6 mm x 105 mm



identification
label

For cardboard boxes: A4 or A5
(for international customer use only)

3.1.2 Containers and pallets

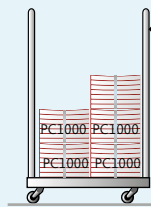

identification
sheet

For containers:
Restmail: A4 or A5

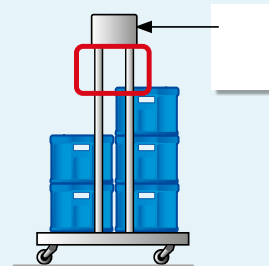

For trays containers:
A4 or A5 or
101.6 mm x 105 mm

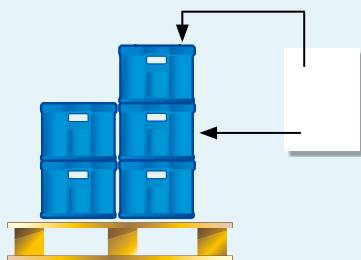

For pallets:
A4 or A5

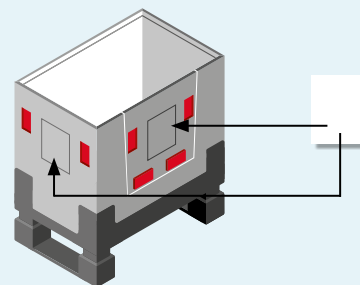

For the Palletbox Mail:
A5 on the 2 label carriers

- The pallet must also have 2 identification sheets:
- 1 sheet on one of the shorter sides of the pallet
 - 1 sheet on top of the pallet





2. Addressed mail > Preparing your mail items - Packaging

3.2 Label content and colours

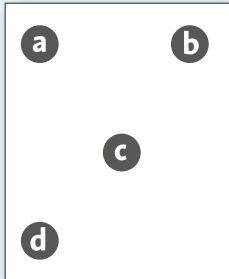

Contents

- **a** customer name (minimum font size: 36)
- **b** deposit number (if available) or unique deposit
- **c** identifiersorted item (depending on sorting type: see the **chapter on Preparing your mail items - Sorting options**).
 - size = minimum 36 (tray label)
 - size = minimum 72 (container/pallet label)
- **d** sorting type

Colour

- black (or dark) font on white

Examples with sorting plan Small V2

Tray label

| Customer name | Deposit number |
|--|----------------|
| Sorting plan number (E.g. Bb-W1-E7) | |
| Sorting plan | |

Container/pallet label

| Customer name | Deposit number |
|--|----------------|
| Sorting plan number (E.g. Bb-W1-E7) | |
| Sorting plan | |



new

4. Dealing with overflow

After sorting, if you still have mail items that you cannot pack in complete trays due to insufficient volume, you can make up overflow trays.

Overflow trays should always be placed in a separate pallet or trays container.

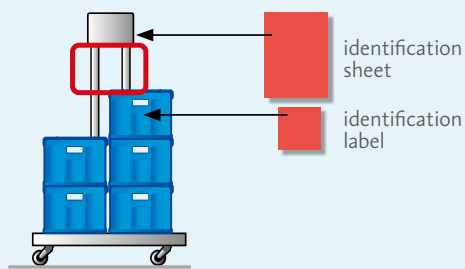

1 overflow container

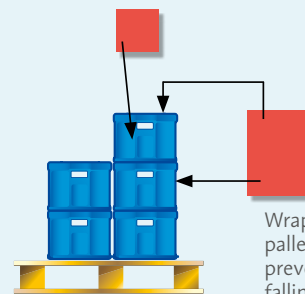

1 overflow pallet

Wrap the trays with the pallet in plastic film to prevent the trays from falling during transport.



1 tray = 1 sorting plan
or
1 tray = overflow

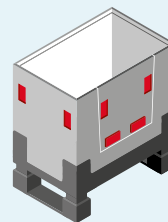

1 Palletbox Mail
= overflow

Exception

If the overflow volume is below

- 10 trays (for packing onto a container) or
- 200 kg or 80 cm high (for packing onto pallets) or
- cannot be embedded in a PalletBox Mail.

it may be placed on top of the container containing mail items of the same sorting type and going to the same destination as the sorted product deposit.

Example

For a national deposit in Brussels X sorted by sorting plan, the overflow volume should be placed on top of a container containing mail items destined for the deposit center of Brussels X.



2. Addressed mail > Preparing your mail items - Packaging

Product identification

- for overflow trays: one red label, marked 'overflow'
- if you have placed the overflow trays on top of a container/pallet:
 - containers are identified using a sheet (A4/A5 format tray label)
 - pallets identified using 2 sheets (A4/A5 format) and marked 'contient des bacs overflow' ['contains overflow trays']
- for overflow containers: an identification sheet (A4/A5 format tray label) marked 'overflow'
- for overflow pallets: 2 sheets (A4/A5 format) marked 'Overflow': one sheet on one of the shorter sides of the pallet and one sheet on top of the pallet
- for the Palletbox Mail overflow: 2 labels marked "Overflow" to be placed on the long side and on the short side, in the transparent label carriers provided for this purpose.

Label content and colours

Please note the special rule for 'overflow' labelling: black (or dark) font on red background
Alternative: red font on white background.

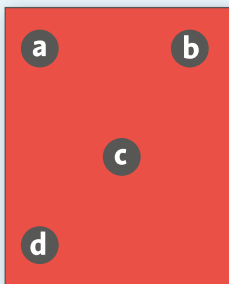

Content

- **a** customer name (minimum font size = 36)
- **b** deposit number (where available) or unique deposit identifier
- for overflow trays **c** and **d**: marked 'Overflow'
- for containers/pallets containing overflow only, and **c** and **d**: marked 'Overflow'
- for sorted containers/pallets with additional overflow
 - **c**: destination of sorted product (depending on sorting type: see **the chapter on Preparing your mail items - Sorting options**) + marked 'Contient des bacs Overflow' ['Contains overflow trays']
 - **d**: sorting type of sorted product

Colour

- black/dark font on red background (or red font on white background)

new

Examples of overflow labels

For the tray

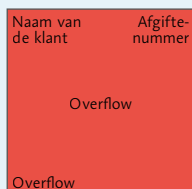

Example of A4/A5 label for a pallet/container or Palletbox containing overflow only

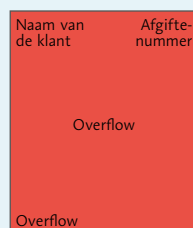

Example of A4/A5 label for pallet/container containing mail items with part of overflow

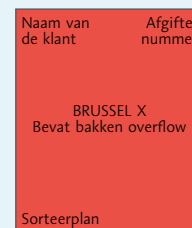

For more information on overflow refer to **point 2 of this chapter**.



Did you know?



- For split or spread deposits, additional information must be included on the labels (details in **points 4.3 and 4.4 of the chapter Depositing your mail items**).
- If you are a mail handler and you make several deposits for different customers at the same time, please refer to **the chapter on Depositing your mail items** for the information to be included on the labels.

5. Important definitions

bpost handles and delivers the post according to a clearly defined segmentation system, based on national postcodes. These are based around distribution offices, taken in by sorting sectors and allocated to sorting centers, of which there are 5 in Belgium.

See the example of Sorting Center distribution below.



Did you know?



There are 5 Sorting Centers in Belgium:
Antwerp X, Brussels X, Charleroi X, Ghent X and Liège X.

- 1 sorting center = several sorting sectors
- 1 sorting sector = several distribution offices
- 1 distribution office = a series of postcodes (for details, see **point 3.2 of this chapter**)

Example of distribution by Sorting center - Sorting sector - Distribution office - Postcodes¹

| Sorting center | Brussels X | | | | | | | | | | | | |
|---------------------|------------|------|-----|-------|------|-----|-------|------|-----|-------|------|-----|------|
| Sorting sectors | 10-12 | | | 15-16 | | | 17-19 | | | 30-34 | | | |
| Distribution office | 1000 | 1020 | ... | 1210 | 1500 | ... | 1600 | 1700 | ... | 1980 | 3000 | ... | 3450 |
| Postcodes | 1000 | | | | | | 1670 | 1700 | | 1980 | | | 3470 |
| | 1005 | | | | | | 1671 | 1701 | | 1981 | 3000 | | 3471 |
| | 1006 | | | | | | 1673 | 1702 | ... | 1982 | 3001 | ... | 3472 |
| | 1007 | 1020 | ... | 1210 | 1500 | ... | 1674 | 1703 | | | | | 3473 |
| | 1008 | | | 1212 | 1501 | | | | | | | | |
| | 1009 | | | | | | | | | | | | |
| | 1011 | | | | | | | | | | | | |
| | 1012 | | | | | | | | | | | | |

¹ These distributions may be subject to regular updates. Please always refer to the website www.bpost.be/masspost.



2. Addressed mail > Preparing your mail items - Packaging

| Sorting center | | Antwerp X | | | | | | | |
|---------------------|-------|-----------|--------------|--------------------|-----|------|--------------------|-----|------|
| Sorting sectors | 20-24 | | | 25-29 ¹ | | | 35-39 ¹ | | |
| Distribution office | 2000 | ... | 2490 | 2500 | ... | 2990 | 3500 | ... | 3990 |
| Postcodes | 2000 | ... | 2490 2491 | 2500 | ... | 2990 | 3500 | ... | 3990 |

| Sorting center | | Liège X | | | | | | | |
|---------------------|-------|---------|------|-------|-----|----------------------|-------|-----|--------------|
| Sorting sectors | 40-44 | | | 45-49 | | | 66-69 | | |
| Distribution office | 4000 | ... | 4480 | 4500 | ... | 4980 | 6690 | ... | 6990 |
| Postcodes | 4000 | ... | 4480 | 4500 | ... | 4980 4983 4987 | 6690 | ... | 6990 6997 |

| Sorting center | | Charleroi X | | | | | | | | | | | | |
|---------------------|--------------|-------------|--------------------------------------|-----|------|----------------------|-----|--|--|-----|------|--|-----|------------------------------|
| Sorting sectors | 13-14 | | 50-56 | | | 60-65 | | | 70-73 | | | 75-79 | | |
| Distribution office | 1300 | 1400 | 5000 | ... | 5600 | 6000 | ... | 6590 | 7000 | ... | 7390 | 7500 | ... | 7970 |
| Postcodes | 1300 1301 | 14.... | 5000 5001 5002 5003 5004 | ... | 5680 | 6000 6001 6010 | ... | 6590 6591 6592 6593 6594 6596 | 7010 7011 7012 7020 7021 7022 7024 7030 7031 7032 7033 7034 | ... | 7390 | 7500 7501 7502 7503 7504 7506 7520 7521 7522 | ... | 7970 7971 7972 7973 |

| Sorting center | | Ghent X | | | | | | | | | | |
|---------------------|-------|---------|------|--------------|-----|------|-------|-----|----------------------|--------------|-----|----------------------|
| Sorting sectors | 80-84 | | | 85-89 | | | 90-94 | | | 95-99 | | |
| Distribution office | 8000 | ... | 8490 | 8500 | ... | 8980 | 9000 | ... | 9470 | 9500 | ... | 9990 |
| Postcodes | 8000 | ... | 8490 | 8500 8501 | ... | 8980 | 9000 | ... | 9470 9472 9473 | 9500 9506 | ... | 9990 9991 9992 |

Please note

The ideal and standard packaging option = containers and the Palletbox Mail for deposits sorted in RSV3.

Pallet packing remains an option.



¹ For operational reasons, mail items **Large(+)** Format and Press with postal codes from sectors 25-29 are processed via the Sorting Centre in Brussels X and mailings for 35-39 via Liège X.



Preparing your mail items - Sorting options

In this chapter we explain how best to prepare your mail items, according to your preferences, production processes and/or possibly your contract. You can choose whether or not to sort your mail items before depositing them at one of our (Hyper) Masspost Centers. Sorting type determines how you should prepare trays, their contents (container or pallets) as well as their labelling prior to deposit (see the summary table at the end of this chapter).

new

Did you know that?



From 2020, bpost will adapt its postal distribution model to enable our postmen to fill your mailboxes more efficiently.

Every day, the postmen will distribute all urgent products (Prior (D+1), parcels, weekly magazines, registered and MaxiResponse) and twice a week, non-urgent (Non-Prior) mail.

Your non-urgent mail will be distributed, depending on the location of your customers,

- either on Monday and Wednesday (= zone a),
- or on Tuesday and Thursday (= zone b).

These 2 references (a or b) will appear in the new sorting plans.

new

1. The different sorting options

Your mail items may be:

- unsorted: deposited without prior sorting
- sorted by sorting plan **Small Format**
 - V1: this sorting plan consists of a series of non consecutive postal codes
 - V2: this sorting plan consists of a series of non consecutive postal codes from the same distribution area (a or b).
- sorted by Round and sequence V3¹: mail items sorted by **Large** and **Large+ Format** sorting plan (bundled by distribution office or arranged unbundled in Palletbox) and arranged by mail round and in ascending sequence order. For more information, **see point 5 in this chapter**.

Examples of sorting type references

| Sorting plan V1 (for Small Format) | Sorting plan V2 (for Small Format) | Round and sequence V3 (for Large(+) Format) |
|---------------------------------------|---------------------------------------|---|
| C-W1-L1 | Ca-W1-L1 or Cb-W1-L1 | Ba-M1-W1/1050-Reg-001/1 or Bb-M1-W1/1050-Reg-001/1 |

¹ Sorting Round and sequence V2 version remains possible until 30/06/2020.



2. Addressed mail > Preparing your mail items - Sorting options

Unsorted

Sorted by sorting plan

Sorted by Round and sequence

Overflow

3. Unsorted mail items

An unsorted deposit means that mail items have not been presorted according to one of the bpost sorting methods (as outlined in this chapter).

3.1 Maximum and minimum volume per deposit

| | Masspost Center | Hyper Masspost Center |
|--|-----------------|-----------------------|
| Unsorted Small Format mail items | 500 > 50,000 | 500 > ... (unlimited) |
| Unsorted Large, Large+ Format mail items | 500 > 20,000 | 500 > ... (unlimited) |

3.2 Packaging and labelling

Trays placed in trays containers/on pallets (also possible : the Palletbox Mail, according to the conditioning rules).

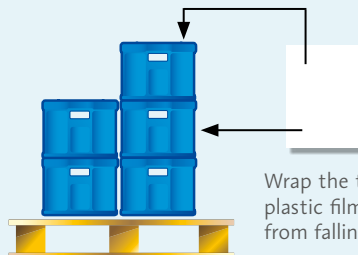
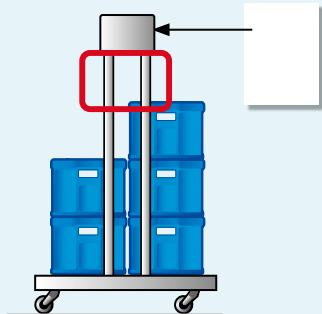

Wrap the trays and the pallet in plastic film to prevent the trays from falling during transport.

Identification of the contents

- for containers: an identification sheet (A4/A5 tray label format)
- for pallets: 2 sheets (A4 or A5): one sheet on one of the shorter sides of the pallet and one sheet on top of the pallet
- for the Palletbox Mail¹: 2 labels to be placed on the long side and on the short side, in the provided transparent label carriers.

A4/A5 Model

| | |
|----------------|----------------|
| Customer name | Deposit number |
| BX Unsorted | |
| Unsorted | |

Information to be included

- customer name (minimum font size: 36)
- deposit number or unique deposit identifier
- sorting centre
- unsorted (minimum font size: 72)
- mail item sorting option: unsorted

¹ Only for Large Format shipments in Hyper Masspost Center.



2. Addressed mail > Preparing your mail items - Sorting options

Unsorted

Sorted by sorting plan

Sorted by Round and sequence

Overflow

new

4. Sorted mail items per sorting plan V1 or V2 (for Small Format)

V1: this sorting plan covers a series of non-consecutive postcodes and has a three-part code, for example:

Sorting plan example: B-W1-E7

Each sorting plan is part of a sorting zone determined by the first two parts of the code. Several sorting plans are covered by a single sorting zone.

Sorting zone example: B-W1

For the product **Direct Mail**, the sorting plan V1 is no longer valid after 30/06/2020.

V2: this sorting plan covers a series of non-consecutive postcodes of the same distribution zone (a or b).

Example of a sorting plan V2 : Ba-W1-E7

The list of sorting plans and sorting zones V1 is available on the website www.bpost.be/masspost.

For sorting V2, the information is only available in the [bpost reply file](#) that is returned when your address file is sent (see chapter **Mail ID Technology of the same section, point 3.1**)

4.1 Maximum and minimum volume per deposit

| | Masspost Center | Hyper Masspost Center |
|---|-----------------|--------------------------|
| Small Format mail items sorted by sorting plan V1 or V2 | 25,000 > 50,000 | 25,000 > ... (unlimited) |



2. Addressed mail > Preparing your mail items - Sorting options

Unsorted

Sorted by sorting plan

Sorted by Round and sequence

Overflow

4.2 Packaging and labelling

4.2.1 In containers/on pallets by sorting plan

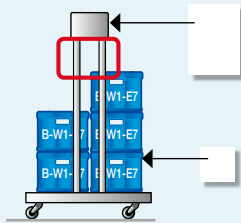

1 container per sorting plan
(E.g. B-W1-E7) (V1)
or Ba-W1-E7 (V2)

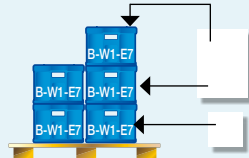

One pallet per sorting plan
(E.g. B-W1-E7) (V1)
or Ba-W1-E7 (V2)



1 tray = 1 sorting plan

Wrap the trays with the pallet in plastic film to prevent the trays from falling during transport.

All mail items should be packaged in trays¹.

Each tray must only contain mail items destined for the same sorting plan. Each container or pallet must only contain mail trays destined for the same sorting plan.

If you do not have enough containers to

- Fill one entire container per sorting plan (at least 10 containers)
- to fill a complete pallet (at least 200 kg or 80 cm high) per sorting plan, see next page, **point 4.2.2**

If you use the V2 sorting plan, the name will be slightly different (the terms distribution zone “a” and “b” have been added). The principle of conditioning remains the same.

Identification of the contents

- for trays: a label
- for containers: an identification sheet (A4/A5 tray label format)
- for pallets: 2 sheets (A4/A5 format): one sheet on one of the shorter sides of the pallet and one sheet on top of the pallet

Model label

| Customer name | Deposit number |
|---|----------------|
| Zone a (for V2) (B-W1-E7 (V1) or Ba-W1-E7 (V2)) | |
| Sorting plan | |

Information to be included

- customer name (minimum font size: 36)
- deposit number or unique deposit identifier
- distribution zone (a or b) (if sorting plan V2)
- sorting centre of destination
- sorting plan number (minimum font size: 36)
- sorting option: sorting by sorting plan

A4/A5 example

| Customer name | Deposit number |
|---|----------------|
| Zone a (for V2) (B-W1-E7 (V1) or Ba-W1-E7 (V2)) | |
| Sorting plan | |

Information to be included

- customer name (minimum font size: 36)
- deposit number or unique deposit identifier
- distribution zone (if sorting plan V2)
- sorting centre of destination
- sorting plan number (minimum font size: 72)
- sorting option: sorting by sorting plan

¹ For international customers only, cardboard boxes of an equivalent size and with a maximum capacity of 7 kg may be used (see the details in Point 1.5 of the Packaging chapter in this section).



2. Addressed mail > Preparing your mail items - Sorting options

Unsorted

Sorted by sorting plan

Sorted by Round and sequence

Overflow

4.2.2 In containers/on pallets by wave

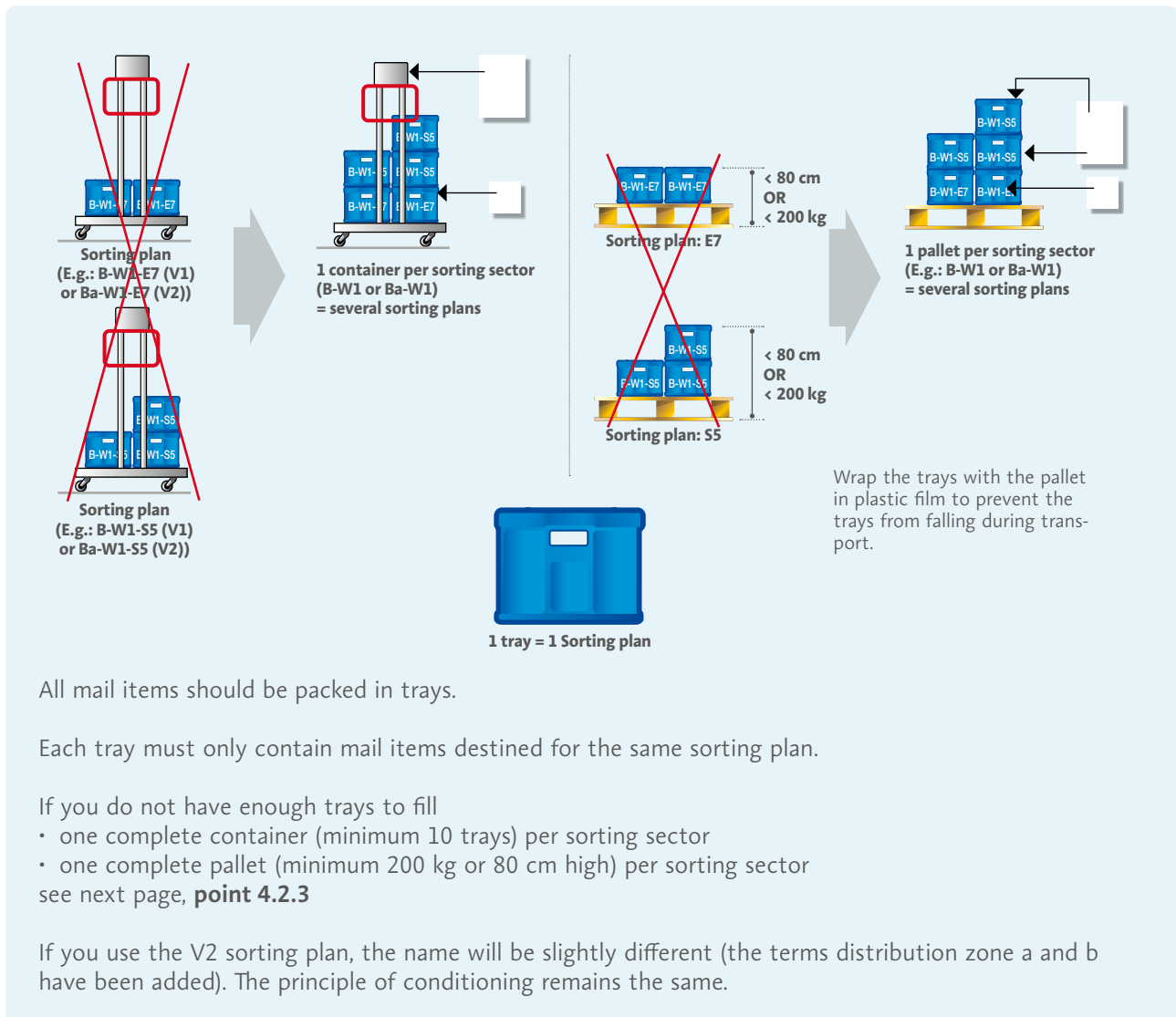

Identification of the contents

- for trays: a label
- for containers: an identification sheet (A4/A5 tray label format)
- for pallets: 2 sheets (A4/A5 format): one sheet on one of the shorter sides of the pallet and one sheet on top of the pallet

Model label

| Customer name | Deposit number |
|---|----------------|
| Zone a (for V2) BX B-W1(V1) or Ba-W1 (V2) | |
| Sorting plan | |

Information to be included

- customer name (minimum font size: 36)
- deposit number or unique deposit identifier
- distribution zone (a or b)
- sorting centre of destination
- sorting wave number (minimum font size: 36)
- sorting option: sorting by sorting plan

A4/A5 example

| Customer name | Deposit number |
|---|----------------|
| Zone a (for V2) BX B-W1(V1) or Ba-W1 (V2) | |
| Sorting plan | |

Information to be included

- customer name (minimum font size: 36)
- deposit number or unique deposit identifier
- distribution zone (a or b)
- sorting centre of destination
- sorting zone number (minimum font size: 72)
- sorting option: sorting by sorting plan



2. Addressed mail > Preparing your mail items - Sorting options

Unsorted

Sorted by sorting plan

Sorted by Round and sequence

Overflow

4.2.3 In containers/on pallets by sorting center

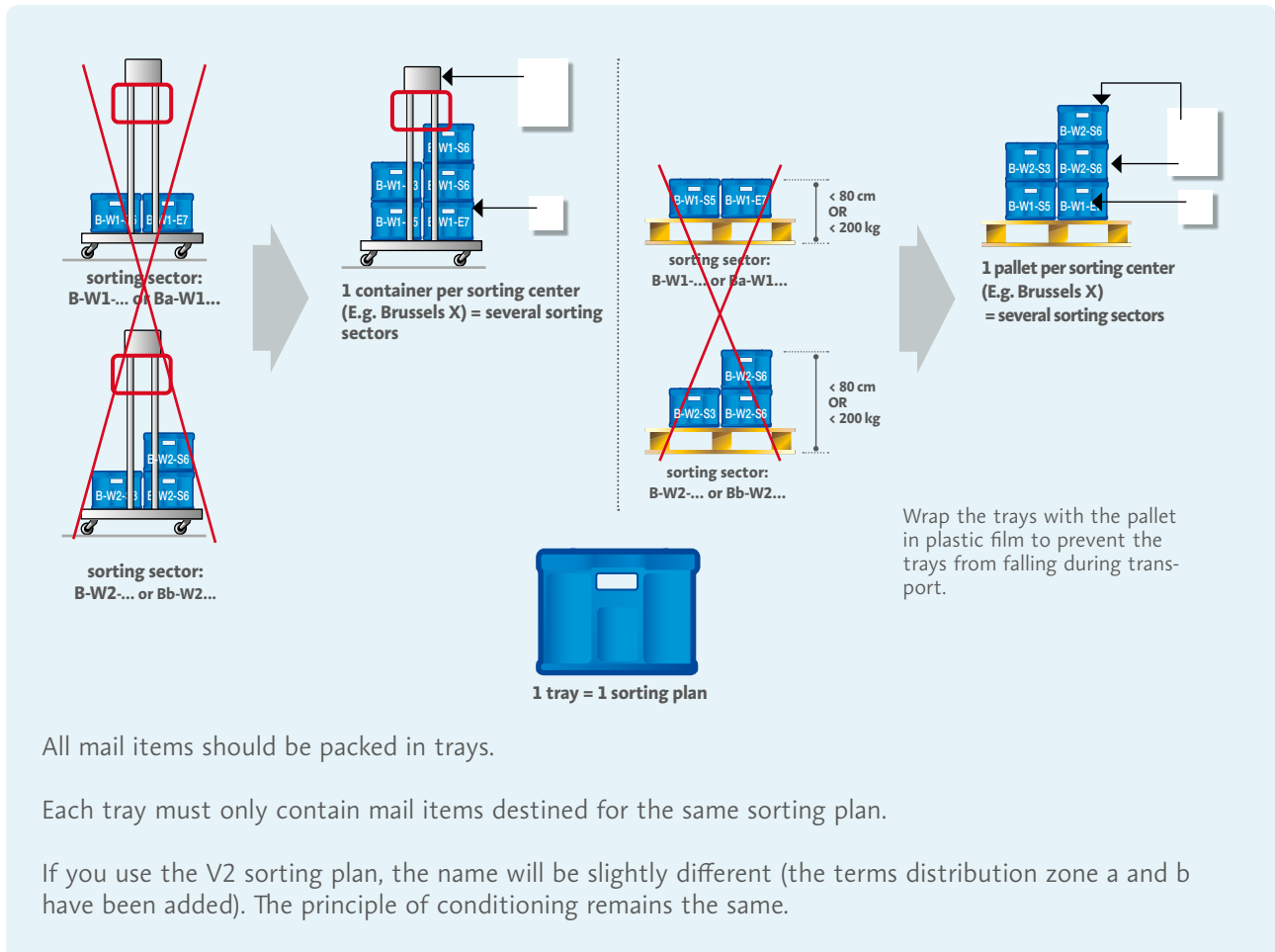

All mail items should be packed in trays.

Each tray must only contain mail items destined for the same sorting plan.

If you use the V2 sorting plan, the name will be slightly different (the terms distribution zone a and b have been added). The principle of conditioning remains the same.

Make sure that the containers destined for different sorting centers are never grouped on the same pallet or container, otherwise they will be considered as overflow (**see point 4.2.4**).



It is permitted to have one container per sorting centre with a mixture of two distribution zones (a and b), only to meet production purposes.

However, the label of the container/pallet must state: "Contains 2 zones a AND b".



2. Addressed mail > Preparing your mail items - Sorting options

Unsorted

Sorted by sorting plan

Sorted by Round and sequence

Overflow

Identification of the contents

- for trays: a label
- for containers: an identification sheet (A4/A5 tray label format)
- for pallets: 2 sheets (A4/A5 format): one sheet on one of the shorter sides of the pallet and one sheet on top of the pallet

Model label

| Customer name | Deposit number |
|---------------|----------------|
| Zone a BX | |
| Sorting plan | |

Information to be included

- customer name (minimum font size: 36)
- deposit number or unique deposit identifier
- distribution zone (if sorting plan V2)
- sorting centre of destination (minimum font size: 36)
- sorting option: sorting by sorting plan

A4/A5 example

| Customer name | Deposit number |
|---------------|----------------|
| Zone a BX | |
| Sorting plan | |

Information to be included

- customer name (minimum font size: 36)
- deposit number or unique deposit identifier
- distribution zone (if sorting plan V2)
- sorting centre of destination (minimum font size: 72)
- sorting option: sorting by sorting plan

Example with 2 distribution zones

| Customer name | Deposit number |
|-----------------------------------|----------------|
| Contains 2 zones a and b BX | |
| Sorting plan | |

Information to be included

- customer name (minimum font size: 36)
- deposit number or unique deposit identifier
- contains 2 zones a and b
- sorting centre of destination (minimum font size: 72)
- sorting option: sorting by sorting plan



Unsorted

Sorted by sorting plan

Sorted by Round and sequence

Overflow

4.2.4 In containers/on pallets in overflow

After sorting, if you still have mail items that you cannot pack in complete trays (per sorting plan) due to insufficient volume, you can make up overflow trays.

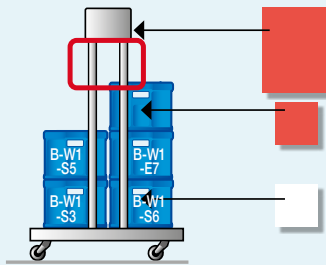

E.g. 1 container per sorting center
= several sorting zones + overflow tray(s)

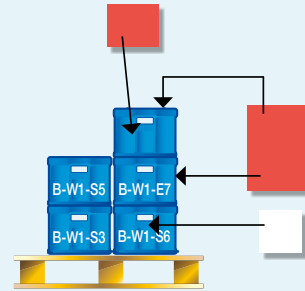

E.g. 1 pallet per sorting center
= several sorting zones + overflow tray(s)

or

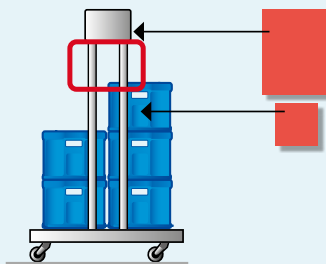

E.g. 1 overflow container

or

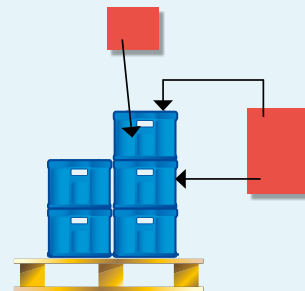

E.g. 1 overflow pallet



1 tray = 1 sorting plan
or
1 tray = overflow

Wrap the trays and the pallet in plastic film to prevent the trays from falling during transport.

To identify containers, pallets and trays containing Overflow, please refer to the **chapter on Preparation of your mail items - Packaging, point 4.**

Model label tray

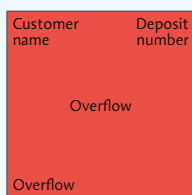

Model A4/A5 containers/ pallets containing overflow

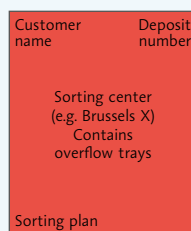

Model A4/A5 overflow containers/pallets

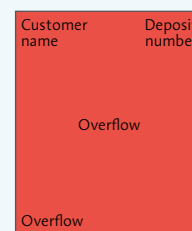



2. Addressed mail > Preparing your mail items - Sorting options

Unsorted

Sorted by sorting plan

Sorted by Round and sequence

Overflow

new

5. Mail items sorted by Round and sequence V3¹

Sorting by Round and sequence is the finest level of sorting. It states the round and delivery distribution sequence on each item and can contain one or more print versions (runs) in the same deposit.²

Preparation for sorting by Round and sequence involves:

- sorting your mail items from the same deposit by **Large Format** sorting plan
- packing your mail items into direct bundles by distribution office (no trays), see **point 5.2**. In each bundle, mail items are sorted in ascending order of rounds and following their sequence.
- OR packing your mail items **NOT in bundles** in **Palletbox Mail** (see **point 5.3**). In this case, the mail items are arranged according to the rounds in ascending order of the sequences (communicated in the response file of bpost).

All this information is transmitted in bpost's response file.

If your delivery is composed of several lots (e.g. due to the segmentation of messages), and that each of them is sorted separately by Round and Sequence, please follow these rules:



- the sorting criteria must be respected within each lot (see **chapter Depositing your mail items, point 1**)
- each lot contains **at least 10,000 items** sorted into a single sequence. This minimum will not apply if the lots are distinguished by the only **language criterion**.

Did you know?

The sequence number or reference refers to the mail items' distribution sequence for each round.



5.1 Minimum and maximum volume per deposit

| | Masspost Center | Hyper Masspost Center |
|---|-----------------|--------------------------|
| Large and Large+ Format mail items sorted by Round and sequence | 10,000 > 20,000 | 10,000 > ... (unlimited) |

For more information on addressing-related technical specifications for mail items sorted by Round and sequence, see the **chapter on Mail ID Technology**.

¹ Sorting Round and sequence V2 version remains possible until 30/06/2020.

² For the definition of a deposit in accordance with the products, please refer to the relevant General Terms and Conditions (www.bpost.be/fr/terms-and-conditions)



2. Addressed mail > Preparing your mail items - Sorting options

Unsorted

Sorted by sorting plan

Sorted by Round and sequence

Overflow

Details on mail item bundling are covered in the **chapter Preparing your Mail Items - Packaging, point 1.2.1.**

Each bundle contains mail items destined for one or more mail rounds, belonging to the same distribution office. Characteristics:

- in each bundle: mail items classified in ascending round order (e.g. Reg-001, Reg-002, Reg-003)
- in each round: mail items classified in ascending sequence order (e.g. Reg-001/1, Reg-001/2, Reg-001/3)
- each mail item bears its own sequence reference.
- the sequence reference and the Mail ID barcode must comply with the addressing rules (see **Mail ID Technology chapter, point 4**).

Did you know?



Mail items sorted by Round and sequence are always packed into direct bundles unless placed in a Palletbox Mail (see **point 5.3** deposit NOT in bundels). Bundles should ideally be placed onto pallets. They may not be placed in trays.
The overflow may not be packed in bundles.



2. Addressed mail > Preparing your mail items - Sorting options

Unsorted

Sorted by sorting plan

Sorted by Round and sequence

Overflow

5.2.2 On pallets/in Restmail containers by sorting machine

1 bundle
= 1 distribution office (e.g. 2000 ... 2999 or 3500 ... 3999)

W1
2000
→ Aa-M1-W1/2000-Reg-001/1
→ Aa-M1-W1/2000-Reg-002/2
→ Aa-M1-W1/2000-.....

2020
→ Aa-M1-W1/2020-Reg-001/1
→ Aa-M1-W1/2020-Reg-002/1
→ Aa-M1-W1/2020-.....

W2
2060
→ Aa-M1-W2/2060-Reg-001/1
→ Aa-M1-W2/2060-Reg-002/1
→ Aa-M1-W2/2060-.....

3500
→ Aa-M1-W2/3500-Reg-001/1
→ Aa-M1-W2/3500-Reg-002/1
→ Aa-M1-W2/3500-.....

W3
3680
→ Aa-M1-W3/3680-Reg-001/1
→ Aa-M1-W3/3680-Reg-002/1
→ Aa-M1-W3/3680-.....

...

One pallet* per sorting machine (e.g. Aa-M1-W1...W3)

One pallet* per sorting machine (e.g. Ab-M1-W1...W3)

Wrap the bundles with the pallet in plastic film to prevent the bundles from falling during transport.

* Packaging also applicable for Restmail containers

All mail items are packaged in direct bundles placed in the pallet/container **in ascending wave order**.

Each pallet or Restmail container must only contain mail items destined for the same sorting center and the same sorting machine.

If you do not have enough bundles to fill

- one complete Restmail Container (minimum 200 kg or half full) per machine
- one complete pallet (minimum 200 kg or 80 cm high) per machine

you can add to it bundles from other machines of the same sorting center **see next page point 5.2.3**.

Identification of the contents

- for Restmail containers: a sheet (A4/A5 tray label format)
- for pallets: 2 sheets (A4/A5 format): one sheet on one of the shorter sides of the pallet and one sheet on top of the pallet

A4/A5 Model

| | |
|---------------------------------|----------------|
| Customer name | Deposit number |
| Zone a AX Aa-M1-W1...W3 | |
| Sorted by Round and sequence V3 | |

Information to be included

- customer name (minimum font size: 36)
- deposit number or unique deposit identifier
- distribution zone (a or b)
- sorting centre of destination
- sorting waves (minimum font size: 72)
- sorting option: sorting by Round and sequence V3



2. Addressed mail > Preparing your mail items - Sorting options

Unsorted

Sorted by sorting plan

Sorted by Round and sequence

Overflow

5.2.3 On pallets/in Restmail containers for the same distribution zone of one and the same sorting center

1 bundle = 1 distribution office (E.g. 2000 ... 2999 or 3500 ... 3999)

→ Aa-M1-W1/2000-Reg-001/1
→ Aa-M1-W1/2000-Reg-001/2
→ Aa-M1-W1/2000-.....

→ Aa-M1-W2/2020-Reg-001/1
→ Aa-M1-W2/2020-Reg-002/1
→ Aa-M1-W2/2020-.....

→ Aa-M2-W2/2060-Reg-001/1
→ Aa-M2-W2/2060-Reg-002/1
→ Aa-M2-W2/2060-.....

→ Aa-M2-W2/3500-Reg-001/1
→ Aa-M2-W2/3500-Reg-002/1
→ Aa-M2-W2/3500-.....

→ Aa-M2-W3/3680-Reg-001/1
→ Aa-M2-W3/3680-Reg-002/1
→ Aa-M2-W3/3680-.....

... Aa-M3-W5/3880-...

One pallet* per sorting center and per zone (a or b) (E.g. Aa-M1-W1, ..., Aa-M3-W5)

Wrap the bundles with the pallet with plastic film to prevent the bundles from falling during transport.

* Packaging also applicable for Restmail containers

All mail items are packaged in direct bundles placed in the pallet/container **in ascending machine and then wave order**, separated by a paper divider.

Each pallet or Restmail container must only contain mail items destined for the same distribution zone of a same sorting center.

Make sure that the bundles intended for different sorting centres are never grouped on the same pallet or container, otherwise they will be considered overflow (see point 5.4).

Identification of the contents

- for bundles: must be separated by sorting machine using a cardboard or paper divider the same size as the floor of the Restmail container or pallet, stating the following criteria:
 - sorting center reference
 - stating 'sorting by Round and sequence V3'
- for Restmail containers: a sheet (A4/A5 tray label format)
- for pallets: 2 sheets (A4/A5 format): one sheet on one of the shorter sides of the pallet and one sheet on top of the pallet

A4/A5 Model

| | |
|---|----------------|
| Customer name | Deposit number |
| Zone a AX (Aa-M1-W1 ... Aa-M3-W5) | |
| Sorted by Round and sequence V3 | |

Information to be included

- customer name (minimum font size: 36)
- deposit number or unique deposit identifier
- distribution zone (a of b)
- sorting center
- different Large or Large+ Format sorting plans (minimum font size: 72)
- sorting option: sorting by Round and sequence V3



2. Addressed mail > Preparing your mail items - Sorting options

Unsorted

Sorted by sorting plan

Sorted by Round and sequence

Overflow

5.2.4 On pallets/in Restmail containers with 2 distribution zones for the same sorting center

It is permitted to have one container per sorting centre with a mix of two distribution zones a and b, only to meet production purposes. In this exceptional case, however, the bundles of two zones are clearly separated by an intermediate sheet, zone a above, zone b below. However, the label of the container/pallet must include the terms: "Contains 2 zones a AND b".

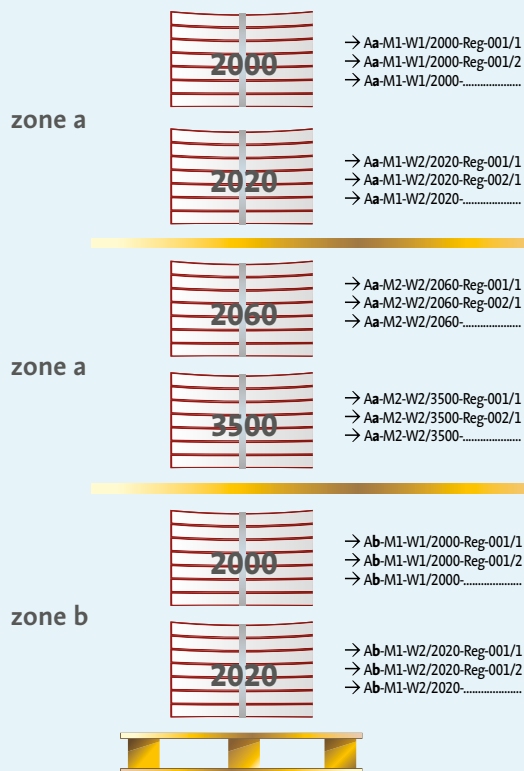

Identification of the container

- for the containers: one sheet (A4/A5 tray label format)
- for the pallets: 2 sheets (size A4 or A5): a sheet on one of the shortest sides of the pallet and a sheet on top of the pallet

Voorbeeld A4/A5

| Customer name | Deposit number |
|--|----------------|
| Contains 2 zones a and b AX Aa-M1 | |
| Sorted by Round and sequence V3 | |

Information to be included

- name of the customer (minimum font size: 36)
- deposit number or unique deposit identifier
- contains 2 zones a and b
- sorting centre
- different **Large or Large+ Format** sorting plans (minimum font size: 72)
- sorting option: sorting by Round and sequence V3



2. Addressed mail > Preparing your mail items - Sorting options

Unsorted

Sorted by sorting plan

Sorted by Round and sequence

Overflow

new

5.3 Deposit NOT in bundles (in Palletbox Mail)

5.3.1 In Palletbox Mail per sorting plan

Each Palletbox Mail contains shipments destined for one or more rounds, belonging to the same sorting plan.

Characteristics :

- Each mail item has its own sequence reference
- The sequence reference and the Mail ID barcode comply with the addressing rules. (see **chapter Mail ID Technology, point 4**).
- All mail items are conditioned in direct Palletbox Mail in the **ascending order as stated in the response file of bpost**. This order corresponds to the rounds and the increasing order of the sequences.

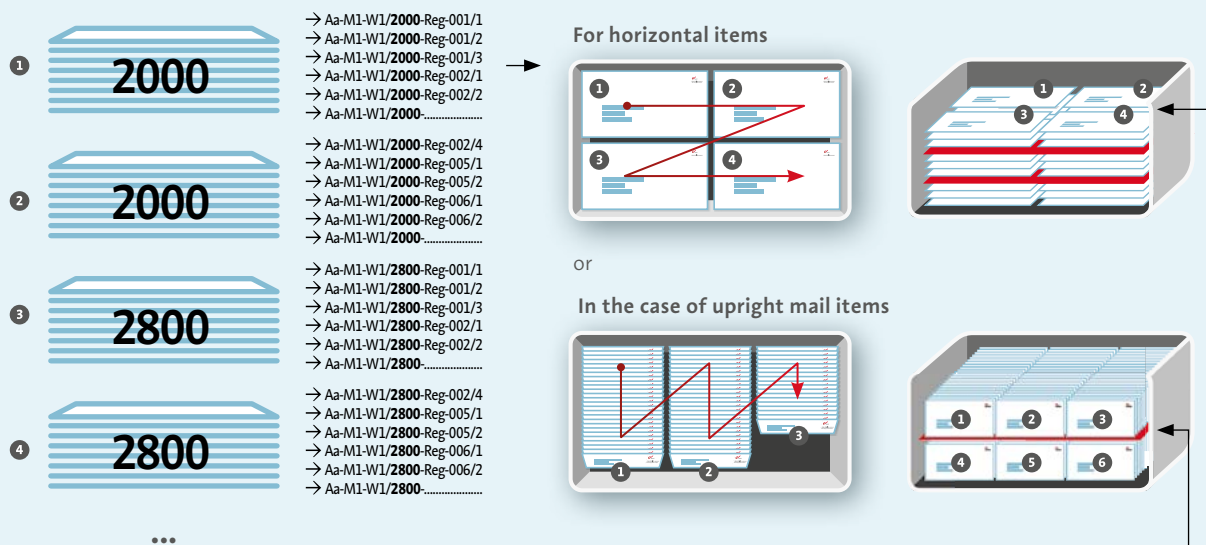

Provide an intermediate sheet between the layers for better stability.



If you do not have enough items to fill a complete Palletbox Mail per **sorting plan** (minimum 80% filling), see **point 5.3.2**.

Identification of the recipient

You can write the Palletbox Mail labels using the Palletbox Mail tool available at www.bpost.be/e-masspost. Place one label on the long side and the other on the short side of the Palletbox Mail in the provided transparent carrier.

Example A5

| Name of the customer | Deposit number |
|--|----------------|
| Zone a AX Aa-M1-W1 (DO from 2000 up to 2800) | |
| Round and sequence RSV3 | |

Information to be included

- name of the customer (minimum font size: 36)
- deposit number or unique deposit identifier
- distribution zone
- sorting center
- Large or Large+ Format sorting plan (minimum font size: 72) with distribution offices
- sorting option: sorting by Round and sequence V3



2. Addressed mail > Preparing your mail items - Sorting options

Unsorted

Sorted by sorting plan

Sorted by Round and sequence

Overflow

5.3.2 In Palletbox Mail per machine

Each Palletbox Mail contains mail items that are destined for the same sorting machine.

All items are conditioned in direct Palletbox Mail in the ascending order as stated in the bpost response file.

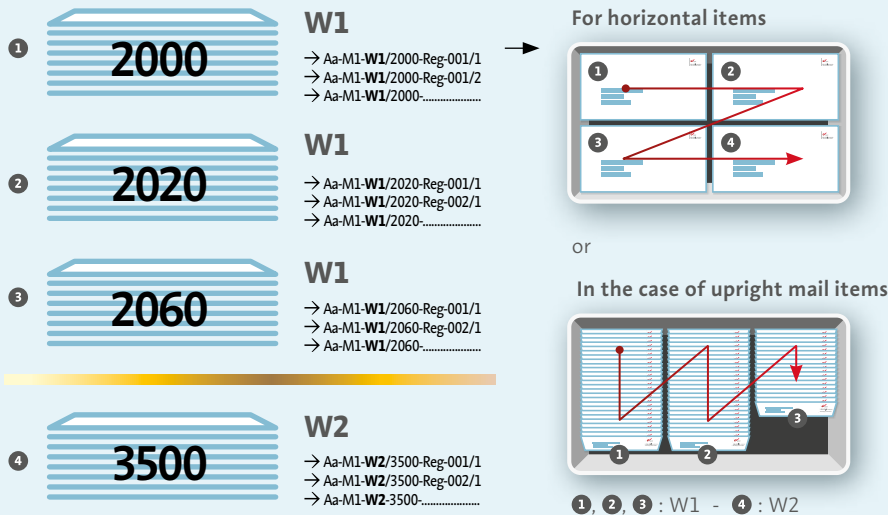

Provide an intermediate sheet between the waves for better stability and separation of sorting



If you do not have enough items to fill a complete Palletbox Mail per machine (minimum 80% filling), see **point 5.3.3**.

Identification of the recipient

You can write the Palletbox Mail labels using the Palletbox Mail tool available at www.bpost.be/e-masspost.

Place one label on the long side and the other on the short side of the Palletbox Mail in the provided transparent carrier.

Example A5

| Name of the customer | Deposit number |
|---------------------------------|----------------|
| Zone a AX Aa-M1-W1 tot W3 | |
| Round and sequence RSV3 | |

Information to be included

- name of the customer (minimum font size: 36)
- deposit number or unique deposit identifier
- distribution zone
- sorting centre of destination
- different sorting plans (minimum font size: 72)
- sorting option: sorting by Round and sequence V3



2. Addressed mail > Preparing your mail items - Sorting options

Unsorted

Sorted by sorting plan

Sorted by Round and sequence

Overflow

5.3.3 In Palletbox Mail of the same distribution zone for one and the same sorting center

Each Palletbox Mail contains mail items destined for the same sorting centre.

All items are conditioned in direct Palletbox Mail in the ascending order as stated in the bpost response file.

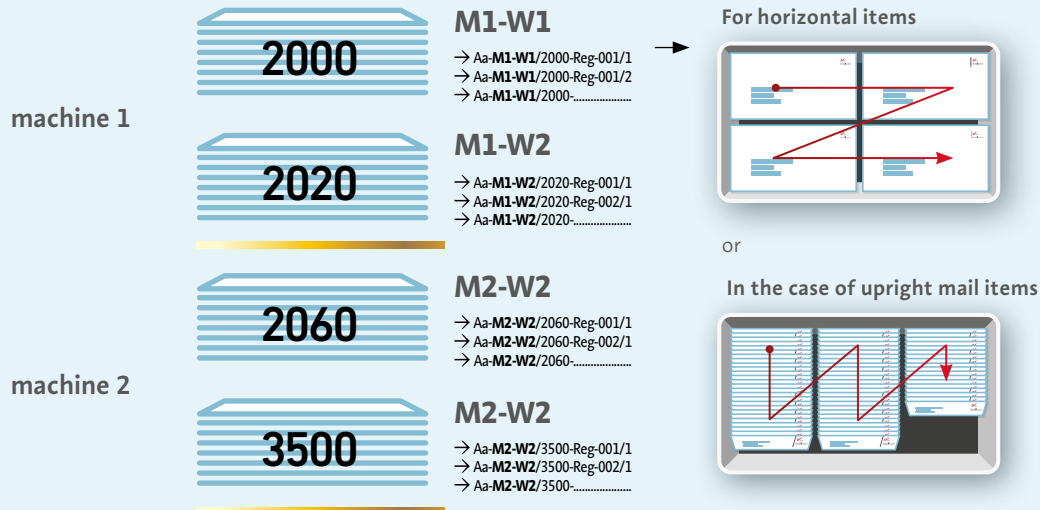

Provide an intermediate sheet between the waves and the machines for better stability and separation of sorting



Never group mail items destined for different sorting centres in the same Pallet Box, otherwise they would be treated as overflow (see point 5.4).



Identification of the recipient

You can write the Palletbox Mail labels using the Palletbox Mail tool available at www.bpost.be/e-masspost.

Place one label on the long side and the other on the short side of the Palletbox Mail in the provided transparent carrier.

Example A5

| Name of the customer | Deposit number |
|--------------------------------|----------------|
| Zone a AX Aa-M1-W1 to W3 | |
| Round and sequence RSV3 | |

Information to be included

- name of the customer (minimum font size: 36)
- deposit number or unique deposit identifier
- distribution zone
- sorting centre of destination
- sorting plan (minimum font size: 72)
- sorting option: sorting by Round and sequence V3



2. Addressed mail > Preparing your mail items - Sorting options

Unsorted

Sorted by sorting plan

Sorted by Round and sequence

Overflow

5.3.4 In Palletbox Mail with 2 distribution zones for the same sorting center

It is permitted to have one Pallet Box per sorting centre with a mix of two distribution zones a and b, only for production purposes. In this exceptional case, however, the bundles of two zones are clearly separated by an intermediate sheet, zone a above, zone b below.

However, the label of the Pallet Box must include the terms : “Contains 2 zones a AND b.

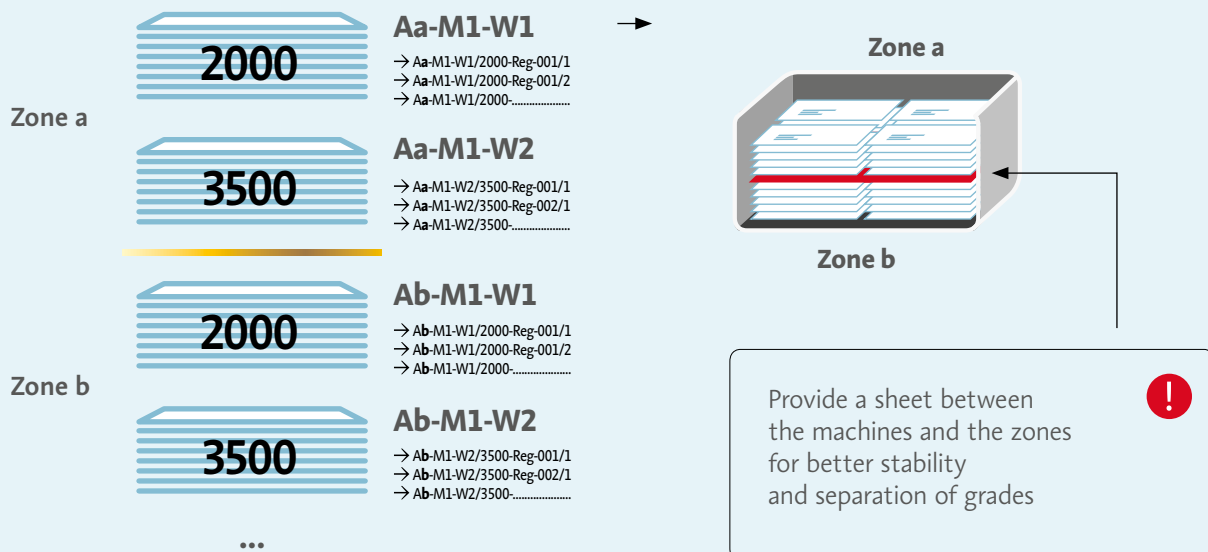

Never group items destined for different sorting centres in the same Pallet Box, otherwise they would be treated as overflow (see point 5.4).

Identification of the recipient

You can write the Palletbox Mail labels using the Palletbox Mail tool available at www.bpost.be/e-masspost.

Place one label on the long side and the other on the short side of the Palletbox Mail in the provided transparent carrier.

Example A5

| Name of the customer | Deposit number |
|-----------------------------|----------------|
| Contains zone a AND b AX | |
| Round and sequence RSV3 | |

Information to be included

- name of the customer (minimum font size: 36)
- deposit number or unique deposit identifier
- statement 'contains zone a AND b'.
- sorting centre of destination
- sorting option: sorting by Round and sequence V3



2. Addressed mail > Preparing your mail items - Sorting options

Unsorted

Sorted by sorting plan

Sorted by Round and sequence

Overflow

5.4 On pallets/in containers with overflow trays

After sorting, if you still have mail items that you cannot pack in direct bundles

- due to insufficient volume,
- or because the distribution office could not be found (system code '0299'), see the **chapter on Mail ID Technology, point 3.**

you can make up overflow trays. The overflow should consequently NOT be bundled.

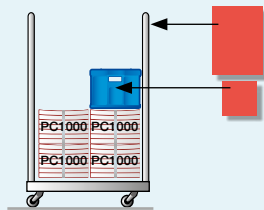

E.g. 1 container per sorting sector = several distribution offices + overflow tray(s)

or

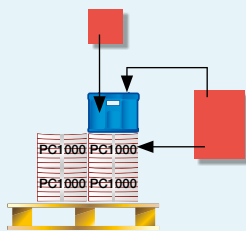

E.g. 1 pallet per sorting machine = A-M1-W1...W3 + overflow tray(s)

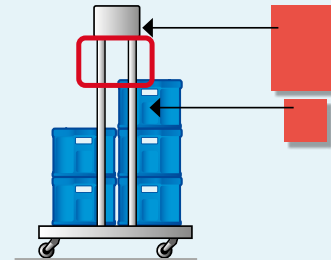

E.g. 1 overflow container

or

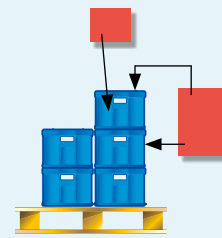

E.g. 1 overflow pallet



1 direct tray = 1 distribution office or
1 tray = overflow

Wrap the trays and the pallet with plastic film to prevent the trays from falling during transport.

To identify containers, pallets and trays containing Overflow, please refer to the **chapter on Preparation of your mail items - Packaging, point 4.**

new

If you use a Palletbox Mail, the overflow is preferably placed in trays that are placed on containers / pallets. If you still want to place the overflow in a Palletbox Mail, please refer to **point 5.3.1 for conditioning**, and put an "Overflow" label on the Palletbox Mail





2. Addressed mail > Preparing your mail items - Sorting options

Unsorted

Sorted by sorting plan

Sorted by Round and sequence

Overflow

Model label tray

| Customer name | Deposit number |
|---------------|----------------|
| Overflow | |
| Overflow | |

Model A4/A5 containers/ pallets containing overflow

| Customer name | Deposit number |
|---|----------------|
| A-M1- W1...W3 Containing overflow trays | |
| Sorting by Round and sequence V2 | |

Model A4/A5 overflow containers/pallets

| Customer name | Deposit number |
|---------------|----------------|
| Overflow | |
| Overflow | |



2. Addressed mail > Preparing your mail items - Sorting options

6. Annex

Tray/container/pallet/Palletbox label

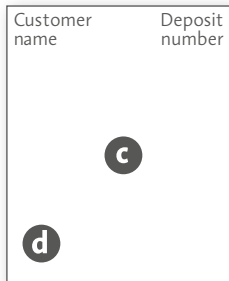

new

| Sorting type | Tray | | Container/Pallet/Pallet-boxMail ^(I) | | Alternative n° 1 ^(II) | | Alternative n° 2 ^(III) | |
|---|--|-----------------|--|---|--|---|--|---|
| | c | d | c | d | c | d | c | d |
| Unsorted | | | Unsorted | | | | | |
| Sorted by sorting plan Small Format V1 | B-W2-L1 (example) | Sorting plan V1 | B-W2-L1 (example) | Sorting plan V1 | B-W2 (example) | Sorting plan V1 | Brussels X or BX (example) | Sorting plan V1 |
| Sorted by sorting plan Small Format V2 | Ba-W2-L1 (example) | Sorteerplan V2 | Ba-W2-L1 (example) | Sorting plan V2 | Ba-W2 (example) | Sorting plan V2 | Brussels X or BX (example) | Sorting plan V2 |
| Sorted by Round and sequence V3¹ Large en Large+ Format | N/A (Bundles) | | Ba-M1-W3 (example) | RSV3 ^(IV) | Ba-M1 (example) | RSV3 ^(IV) | Brussels X or BX (example) | RSV3 ^(IV) |
| Overflow (full) | Overflow (= if one tray, otherwise mention only on the container/pallet) | | Overflow | | | | | |
| Contains overflow | Overflow | | B-W2-M3 or Ba-M1-W3 or ... (example) "contains overflow" | Sorting plan V1 or V2 or RSV3 ^(IV) | B-W2 or Ba-W2... (example) "contains overflow" | Sorting plan V1 or V2 or RSV3 ^(IV) | Brussels X or BX (example) "contains overflow" | Sorting plan V1 or V2 or RSV3 ^(IV) |

(I) Containers/pallet: Where complete containers/pallets are destined for the same sorting center, it is recommended that the name of the sorting center be added to the label.

(II) Alternative 1: if you don't have enough mail items to fill one complete container (minimum 10 trays) or one complete pallet (min 200 kg or 80 cm high) as per Group 1, you can add to it trays as per Alternative 1.

(III) Alternative 2: if you don't have enough mail items to fill one complete container (minimum 10 trays) or one complete pallet (min 200 kg or 80 cm high) as per Group 2, you can add to it trays as per Alternative 2

(IV) Round and sequence V3.

¹ The sorting Round and sequence V2 remains available until 30/06/2020.

Depositing your mail items

This chapter sets out the deposit process and describes the e-Masspost online app (you can use this to schedule and announce your deposits).

1. Definition of a deposit

A deposit is a physical handover of mail items.

All deposits must be accompanied by a deposit **authorisation** or a **deposit statement**.

This document is available online www.bpost.be/masspost (in the deposit scheduling and announcement section).

1.1 Definition of a deposit

new

A deposit includes mail items

- of 500 items or more
- from the same
 - delivery period (for products Letters (Admin) or Clean Mail: D+1, D+3, D+4, Prior or Non Prior whether
 - distribution period (for the product Direct Mail): Distribution Monday & Tuesday, Distribution Wednesday & Thursday or Distribution Week Certain
- in **Small, Large** or **Large+ Format**
- of the same dimensions¹, packaging and format (**Small, Large** or **Large+**)
- subject to the same sorting type
- bearing a return address situated in Belgium on each item
- deposited in trays and/or containers supplied by bpost²
- deposited in a (Hyper) Masspost Center, depending on the volume

¹ The rule about the same dimensions does not apply to **Small Format** 'letter' type items.

² In the case of a foreign sender, the deposit may be done in cardboard boxes.

new

1.2 The various stages of a deposit (depending on the product)



Did you know ?

From 2020, bpost will adapt its distribution model. For some products, you will have to choose the distribution period. Depending on your choice, you will have to deliver your products on a specific day.

Postmen will distribute all urgent products (Prior (D+1), parcels, weekly magazines, registered and MaxiResponse) every workday and will distribute non-urgent mail twice a week.

Your non-urgent mail will be delivered, depending on the location of your customers

- on Monday and Wednesday (= zone a) or
- on Tuesday and Thursday (= zone b).

These 2 references (a or b) will appear in the new sorting plans.

Example of a Direct Mail schedule



Booking

- In e-Masspost up to **5 working days** before deposit.¹

















Deposit

- Choice at the time of Booking, according to the chosen delivery period:
 - Wednesday **or** Thursday
 - Friday **or** Monday
 - Thursday **or** Friday



Distribution

- in 2 days
 - Monday & Tuesday
 - Wednesday & Thursday
- or Week Certain (during the week)

| MON | TUE | WED | THU | FRI | SAT | SUN | MON | TUE | WED | THU | FRI |
|-----|-----|--|--|---|-----|-----|--|---|---|---|-----|
| | |  or  | | | - | - |  |  | | | |
| | | | |  | - | - | or  | |  |  | |
| | | |  or  | | - | - |  |  |  |  | |

The deposit takes place on D-2 or D-3 with respect to the first day of distribution. In weeks with public holidays, the distribution day could be changed. In this case we refer you to our website

www.bpost.be/masspost.

¹ 30 calendar days from a volume of 200,000 pieces.

2. e-Masspost, the online app for scheduling and announcing your deposits

e-Masspost is a completely free online app available from the bpost website www.bpost.be/e-masspost. It ensures that both you and bpost can better manage your deposits, schedule your deposits and create your deposit authorisation. Its use is mandatory for certain items.

2.1 Services available via e-Masspost

- Managing your deposits (e.g.: Pre-Booking, Booking and Announcement).
- Tracking your deposits online (even when you work with third parties).
- Viewing your contracts.
- Downloading your deposit data.
- Managing user access (internal and external) to the application.
- Requesting and managing pre-approval requests for Direct Mail specimen content.

Did you know?

You can request your user account from your sales contact or by calling the Service Center on **02 201 11 11**. For more information, see the e-Masspost guide on our website www.bpost.be/e-masspost.



3. Process for scheduling a deposit

3.1 Basic rule

The scheduling of deposits is mandatory for volumes upwards of

- 100,000 items (**Small Format**)
- 50,000 items (**Large** or **Large+ Format**)

In such cases, deposit information must be submitted via e-Masspost at least 5 working days before the deposit.

For volumes lower than those specified above, scheduling is optional.

In some cases, scheduling can result in operational savings as set out in the General Terms and Conditions for Addressed Mail Items¹.

3.2 For certain bpost items¹, there is a required scheduling process

Failure to follow these scheduling rules may slow down your deposit operationally without prejudice to the Terms and Conditions of bpost or the Terms and Conditions for Addressed Mail Items (Domestic), and/or result in an item being redefined in a different item category.



3.2.1 What is Booking?

- It is the scheduling (reservation) of a deposit via the e-Masspost app.
- This stage enables bpost to conduct the requisite forward planning for the optimal organisation and processing of deposits.

3.2.2 When is Booking compulsory?

- If Booking is part of the definition of the product criteria¹
- For volumes from
 - 100,000 items (**Small Format**)
 - 50,000 items (**Large** and **Large+ Format**)

3.2.3 When should Booking information be submitted?

- General rule: at the latest 5 working days before the deposit.²
- **Exception to the rule:** at least 30 calendar days before deposit (with the option of an approved split deposit - see below) from a volume of 200,000 items (**Small, Large** or **Large+ Format**)
In this case bpost may contact you to agree scheduling of a split deposit with a view to avoiding an overload of capacity that may compromise the handling and/or distribution of mail items in time ('agreed split deposit'). For full details, please refer to **point 4.4 of this chapter**. If this announcement deadline is not met, the normal distribution deadlines applicable to the mail items concerned cannot be guaranteed.

¹ Our General Terms and Conditions and product specifications (available respectively from www.bpost.be and www.bpost.be/directmail) contain all the product definitions and stipulate when scheduling is required.

² Special case for DM Intense: at the signing of the contract.

new

3.2.4 What information is provided at Booking?

- bpost product
- Item format
- Sorting type
- Unit weight(s)
- Franking method
- Total volume of the deposit (or volume per partial deposit in the case of split deposits)
- Recipient address file(s) associated with the deposit (if applicable)
- Date of deposit relating to the distribution period determined by the product
- Place of deposit
- Invoice address
- The reference you wish to appear on the invoice. Optional information:
 - invoice group
 - subcontractor
- Time segment for the deposit and distribution of volumes throughout the day (in the case of spread deposits)
- Packaging type (if applicable)
- Number of containers or pallets (if applicable)
- Number of units per tray or bundle (if applicable)
- Overflow volume (if applicable)
- Dimensions (if applicable)

Under certain terms, it may be possible to change some of your Booking settings.
For more information, contact your Account Manager or the Service Center on **02 201 11 11**.



4. The deposit announcement process

All deposits are subject to the announcement process. It may or may not be subject to the scheduling stage (it is compulsory or optional depending on the product and deposit volume). Once the approval is announced you may obtain deposit authorisation.

There are two ways to get deposit authorisation

- via the e-Masspost app > you print your deposit authorisation in advance (thereby saving time)
- at the Masspost counter > you fill out the Announcement Statement¹ (available at the counter or from www.bpost.be/masspost) and submit it to the counter staff

A deposit made at a (Hyper) Masspost Center must always be accompanied by:

- a deposit authorisation or a deposit statement
- two specimens of the mail items² (for Direct Mail deposits)

In the case of a Mixed Weight deposit for DM Boost and DM Intense solutions, one specimen for each different weights is needed.

Did you know?

Has your deposit been scheduled via Booking? If so, you can retrieve this information from 'Overview Deposits' in the e-Masspost app. The information in the announcement statement must correspond to the actual characteristics of the physical deposit. In the event of an error, the information on the **deposit summary** shall be deemed correct.



4.1 Making an appointment

Please make an appointment with a (Hyper) Masspost Center (by phone or email) to ensure your deposit goes smoothly.

Contact information is given in the **General Annexes** and is also available at www.bpost.be/masspost.

Deposit information to be supplied to your (Hyper) Masspost Center

- Customer details: your business name, plus name and phone number of one contact person
- The (Hyper) Masspost Center chosen for your deposit
- Desired deposit date (the agreed time and date of deposit will be confirmed)
- Desired deposit time (we will check whether this time is available before giving a definitive confirmation)
- Number of mail items: one or more deposits and the total number of mail items per deposit
- Specific packaging method: number of pallets and/or containers you will deliver
- bpost product type
- Any remarks

¹ Announcement statements are available in the **General Annexes, point 5**, Announcement Statement and on the website www.bpost.be/masspost.

² For Direct Mail deposits with different senders and/or different content, a specimen of each component of the deposit must be validated beforehand.

4.2 Obtaining your deposit authorisation

4.2.1 via e-Masspost

If you have not been through the scheduling stage, you may use the e-Masspost app to take you through the 4-step deposit process for gaining deposit authorisation. Please refer to the e-Masspost user manual at www.bpost.be/e-masspost.

4.2.2 via the Masspost counter

- Get a deposit statement (available from the (Hyper) Masspost Center counter or from www.bpost.be/masspost).
- Complete it fully and accurately (product type, quantity, packaging, etc.).
- Take it to a (Hyper) Masspost Center desk.
- You will then receive your deposit authorisation.

4.3 Special case of a spread deposit

A spread deposit is the deposit of mail items sent at different times on the same day from a single (Hyper) Masspost Center.

4.3.1 Spread deposit terms and conditions

- Mail items must be deposited on the same day at the same (Hyper) Masspost Center.
- Different mail items must be covered by the same deposit authorisation (or deposit statement).
- Minimum number of mail items:
 - 20,000 items (**Small Format**)
 - 5,000 items (**Large** and **Large+ Format**)
- The entire deposit must comply with the deposit conditions defined per product¹.

Did you know?



- Only customers who pay by invoice have the option of spread deposit.
- Depending on its available processing capacity, bpost may automatically request spread deposits across one day for deposits upwards of:
 - 100,000 items (**Small Format**)
 - 50,000 items (**Large** and **Large+ Format**)

Overflow (definition given in the chapter on **Preparing your Mail Items - Packaging, points 2 and 4**) for spread deposits: 

The overflow volume for all mail items sorted and deposited according to the terms of a spread deposit is calculated based on the total volume of the spread deposit after receipt of the last part of the deposit.

¹ You can find more information on the terms and conditions for grouped mail items in a single deposit on the product sheets on our website www.bpost.be.

2. Addressed mail > Depositing your mail items

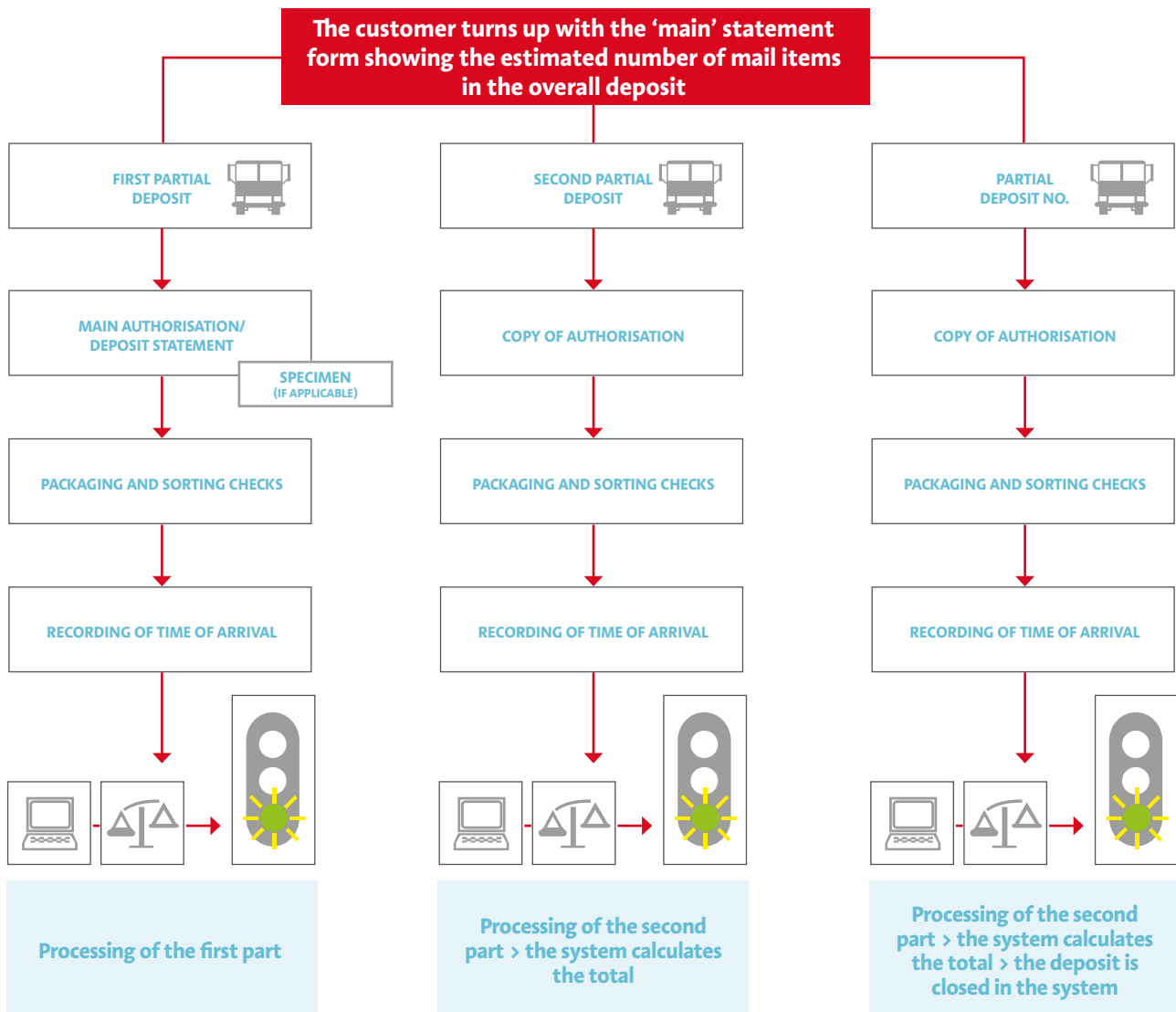

4.3.2 Procedure to be followed for spread deposits

- Announce the number of partial deposits you intend to make in advance. The minimum number of mail items in each partial deposit must be clearly agreed upon, except for the final partial deposit.
- During the 1st partial deposit, submit a deposit authorisation/statement, stating:
 - the number of mail items in the total deposit
 - the indication 'spread deposit'
 - the number of partial deposits
 - that it is a partial deposit (e.g.: '1 of 3' if it is the first part of a total of 3 spread deposits)
- Clearly identify each container with a reference to the deposit authorisation which indicates which part of the spread deposit it is (e.g.: 1 of 3).
- The first partial deposit is handled entirely at the (Hyper) Masspost Center and sent to the sorting center for handling.
- From the 2nd partial deposit, submit a copy of the authorisation/statement, stating which part of the spread deposit it is.
- The 2nd partial deposit is handled entirely at the (Hyper) Masspost Center (the system adds the data of the 2nd partial deposit to the data of the first partial deposit).
- During the final partial deposit, the actual total (the sum of all partial deposits) is compared with the announced number. The figures are adjusted in the system and the deposit is closed.
- Invoices are drawn up based on data approved by bpost.

4.3.3 Identification of containers/pallets

For identification purposes, labels must be used on the various containers and pallets of a spread deposit (linked to the same authorisation/statement).

Label format reminder



- containers: an identification sheet (A4/A5 tray label format)
- pallets: 2 sheets (A4/A5 format): one sheet on one of the shorter sides of the pallet and one sheet on top of the pallet

Labelling of containers/pallets for partial deposit 2 (example)

| | |
|-------------------------------------|----------------|
| Customer name | Deposit number |
| Sorting center (E.g. Brussels X) | |
| Partial deposit (B) of (C) | |
| Sorting plan | |

Information to be included

- customer name (minimum font size: 36)
- deposit number or unique deposit identifier (e.g. Deposit 7506/1234 (A) in example shown below)
- destination of sorted item (content identification in accordance with sorting type - see the 'Sorting Option' paragraph)
- partial deposit (B) of (C) (in the example: 2 of 3, if it is the second partial deposit of a total number of three partial deposits (minimum font size: 72))

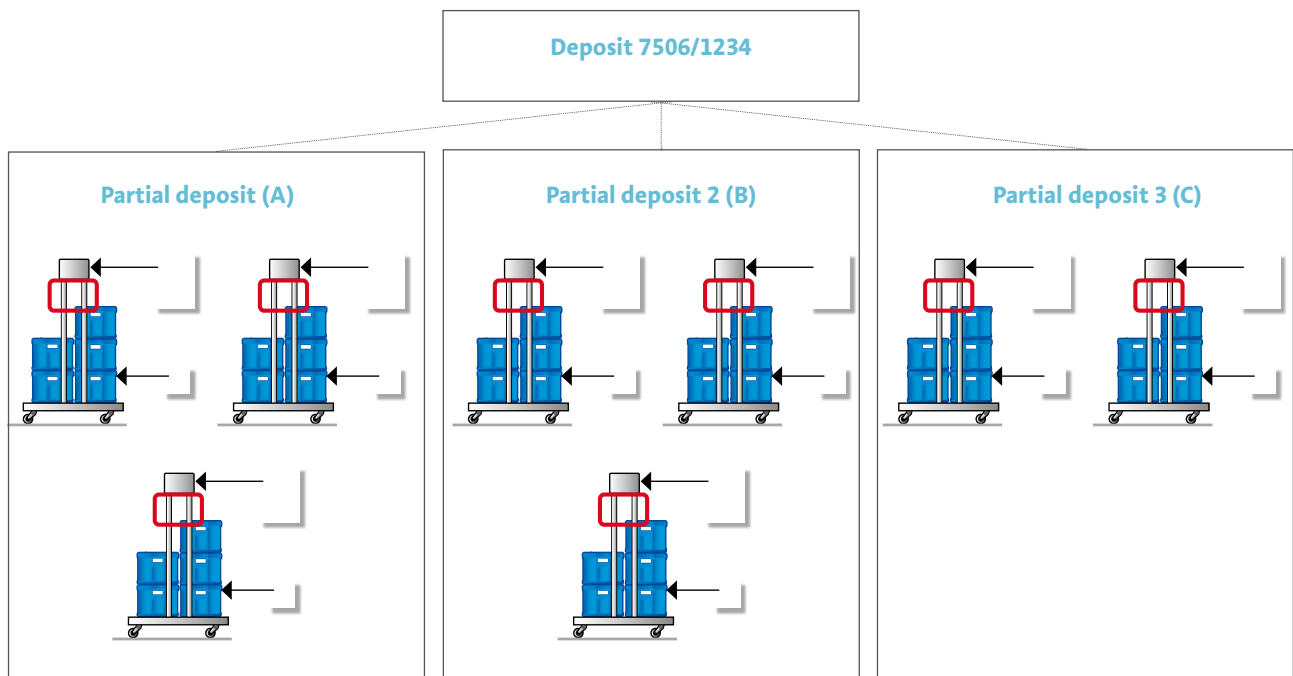

new

4.4 Special case of split delivery (Split Drop)

In the case of a split delivery, the mail items are delivered in one or more (Hyper) Masspost Centers over several working days (maximum 3 consecutive days), while maintaining the initial delivery period for all mail items.

Purpose: to avoid an overload of the capacity (which could jeopardise the usual processing and/or delivery times of the shipments).

The conditions for a split release depend on the product

The same tariff conditions shall apply to the split deposits as to a single-day drop.

- Booking discount (if applicable) on the total volume of the deposit.
- Sorting/Sortsize/Dropsizesize discount (if applicable) on the total volume of the deposit

The total deposit is given a unique reference number

4.4.1 Conditions of the agreed split-off delivery

If bpost and the customer agree on a schedule to split the delivery, this is an **agreed split drop**.

Did you know?

- The agreed split drop is mandatory in the case of a Direct Mail of more than 100,000 items with a unit weight of more than 1 kg.
- Only customers with a payment term can make a split drop.



a DM Easy and DM Boost

- Deposit in a single (Hyper) Masspost Center.
- Announcement of deposit in the e-Masspost application at least 30 calendar days before the date of deposit.
- Minimum number of shipments: 200,000 (**Small, Large or Large+ Format**).
- You can proactively propose a schedule for the split drop at least 10 working days before the date of delivery:
 - sending the schedule to smb_forecasting@bpost.be
 - follow-up of your request within 2 working days
- bpost can contact you to draw up a plan for the split drop together.
 - The initial delivery period is retained for all shipments (storage by bpost):
 - Over a period of up to 3 consecutive days (including the expected delivery date)
 - The last deposit **cannot** be made **on the day before the distribution** period.
 - depending on the available capacity
 - each partial deposit contains a minimum number of items: 100 000 (**Small, Large or Large+ Format**).
- Before the date of the first day of the requested split drop, bpost shall enter the deposit into the system. The 'split drop' entry and the new delivery date appear in the e-Masspost application and on the deposit authorisation.
- A deposit authorisation is required for all partial dispensations.
- The complete deposit must comply with the product's deposit conditions.¹

¹ For more information on the characteristics defined for each product please visit our website as well as the product sheets at www.bpost.be/directmail and www.bpost.be/adminmail under the 'Details' tab.

2. Addressed mail > Depositing your mail items

If no general agreement is reached, the following rules apply:

- If the full deposit is carried out in one day, despite bpost's express request to split the drop due to a limited capacity on that day, the customer benefits from Booking/Sortsize/Dropsizesize discount (if applicable) on the total volume of the delivery. However, the usual delivery times are not guaranteed.
- If the deposit is spread over several days, each partial delivery will be considered as a separate deposit (and invoiced as such).

If the agreed deposit schedule is not complied with, each partial drop will be considered a separate deposit and will be invoiced as such.

b DM Intense

- Announcement in the e-Masspost application.
- Deposit on a maximum basis for the two days corresponding to the distribution period
- In one or more (Hyper) Masspost Centers
- Minimum number of items:
 - 100,000 (**Small Format**)
 - 50,000 (**Large Format**)
- A deposit authorization for each partial deposit.
- A single partial drop per day and per deposit location.
- The entire deposit must comply with the deposit conditions defined per product.

4.4.2 Identification of containers/pallets

If e-Masspost does not give you the option of announcing your volumes per day due to the characteristics of the products in question, see the rules summarised in **point 4.3 Spread Deposit**.

Labels for trays (example)

| | |
|---------------|---|
| Customer name | Deposit number or unique deposit identifier Y |
| Destination | |
| Sorting plan | |

Information to be included

- customer name (minimum font size: 36)
- deposit number or unique deposit identifier
- destination of sorted product (in accordance with appropriate sorting type - see the **Sorting Options chapter**) (minimum font size: 36)
- sorting type

Label for the container or pallet (example)

| | |
|-----------------------------------|---|
| Customer name | Deposit number or unique deposit identifier Y |
| Sorting center (E.g.: Brussels X) | |
| Sorting plan | |

Information to be included

- customer name (minimum font size: 36)
- deposit number or unique deposit identifier (e.g. Deposit number Y in the example schedule above)
- destination of sorted product (in accordance with appropriate sorting type - see the **Sorting Options chapter**) (minimum font size: 72)
- sorting type

Please note

If you make several deposits at the same (Hyper) Masspost Center on the same day, please indicate the field 'Sub-deposit B of C' as explained in **point 4.3 Spread deposit**.

✉ 2. Addressed mail > Depositing your mail items

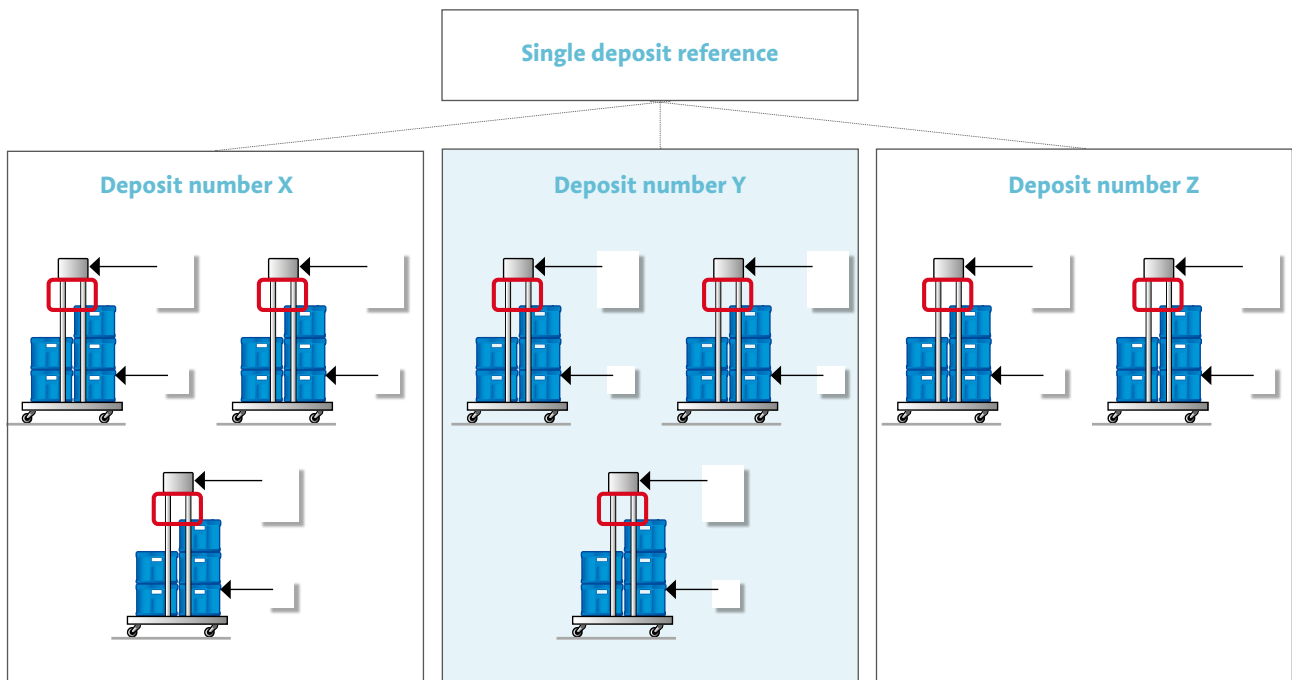

new

4.5 The “Mixed Weight”

With the “Mixed Weight” you can deliver mail items of different weights within the same deposit under certain conditions, namely:

- Only available for DM Boost & DM Intense solutions.
- Same format, size & packaging
- Postage only via PB/PP or UV/RD
- The exact quantities per unit of weight must be communicated.
- The difference between the lightest and heaviest mail items shall not exceed 20%.

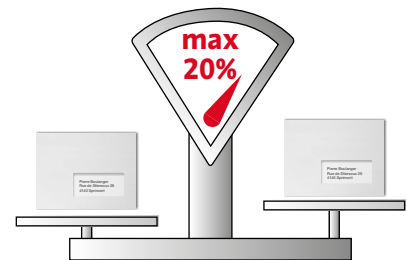

Example:



If the heaviest item weighs **85 g**



$85 \text{ g} \times 20\% = 17 \text{ g}$



Then the lightest mail item can weigh at least $(85-17=)$ **68 g**

In this example, therefore, shipments between **68 g** and **85 g** are also accepted.

5. Deposit and time of deposit

- All deposits shall be made at the (Hyper) Masspost Center.
- Please ensure you have your deposit authorisation and other requisite documents.
- To guarantee the timely delivery of your mail items, the deposit must be made at the (Hyper) Masspost Center at the agreed time.
- Customers that have made an appointment shall be given priority treatment.

You can see the deposit times in **General Annexes, point 3**. You can also consult all the geographical and time data of our centres via <http://www.bpost2.be/locations/business/nl/both.php>.

6. Deposit checks on the dock

Quality and quantity checks are performed:

- barcode scanning of your deposit authorisation
- comparison of physical deposit with data entered on the deposit authorisation
- check of deposit weight
- quality check information entered into the e-Masspost system

bpost reserves the right to adjust the deposit data as announced by the customer, based on the actual physical deposit.

7. Deposit summary

After checks have been made, bpost will give you a deposit summary.

This contains all the information on your deposit. The deposit summary should be retained as it is the **only admissible document** in the event of an invoicing query (queries should be sent to the Service Center¹).

All deposit summaries may be consulted and printed out in the e-Masspost app.

For deposits not made via the e-Masspost app, summary documents can be printed by the (Hyper) Masspost Center.

8. Payment

The following payment methods are available

- cash (limited to 3000 euros per deposit²)
- via electronic payment

Subject to approval by our financial services, a payment term may be granted (invoicing).

For more information, contact our Service Center¹.

¹ See **General Annexes, point 1 How to Contact bpost?**

² In accordance with article 21 of the Law on the Prevention of the Use of the Financial System for the Purposes of Money Laundering and Financing Terrorism.

9. Packaging exchange procedure

The following rules of exchange are designed to ensure the optimal quality of your pallets, containers, trays and bags.

9.1 Pallets

bpost uses standard Europallets (pallet dimensions EUR = 0.8 x 1.2 m). Pallets will be checked at the unloading dock during delivery. The pallets must be perfectly intact in order to be exchangeable.

Pallets are exchanged when you make your deposit at a (Hyper) Masspost Center. The CMR document (waybill) is signed by a bpost employee and yourself. You then leave with other pallets and a copy of the document.



Dimensions: EUR pallet = 800 x 1200 mm

The CMR document states

- date of exchange
- number of pallets received
- number of pallets returned
- any reason why fewer or no pallets have been exchanged

Did you know?

The use of a CMR document is compulsory in Belgium > in the absence of this document, the (Hyper) Masspost Center reserve the right to reject the deposit or the exchange. The CMR document is also used for exchanges made within the framework of bpost's Transport service.



It is not possible to exchange:

- non-standard Europallets
- pallets other than Europallets
- disposable pallets or CHEP, LPR and other pallet pool systems



2. Addressed mail > Depositing your mail items

9.2 Containers, blue trays and Palletboxes Mail

Containers, blue trays and Palletboxes Mail are for mail transport use only and remain the property of bpost. They are exchanged when you make a deposit at a (Hyper) Masspost Center using a CMR document.

If you have a specific need, you can request collection on demand at the (Hyper) Masspost Centers (see the **General Annexes, point 2** for a list of centers).

A Transport can also be made on demand (see details in Transport in **section 9, Collection Services, point 4** or ask at a (Hyper) Masspost Center).

For Palletboxes Mail, the request and collection can only be done via (Hyper) Masspost Centers.

9.3 Bags

Bags are used within the framework of our **Collect & Transport** service. For more information, see **Section 9 - Collection Services**.